

# ATyS d

## Motorised Changeover Switch

Instruction Manual

FR EN DE IT ES NL PT RU PL TR ZH

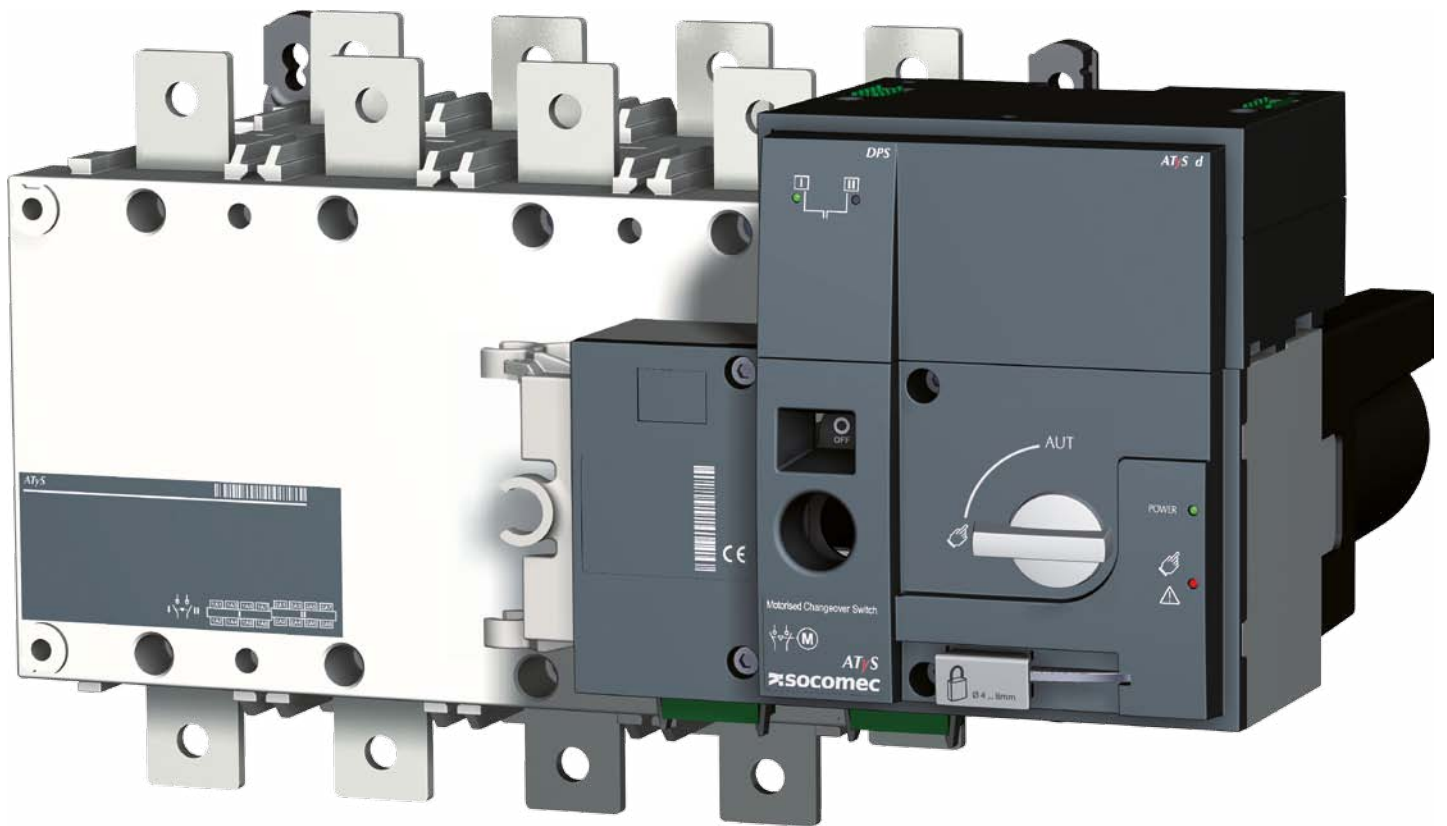

[www.socomec.com](http://www.socomec.com)  
To download, brochures, catalogues and technical manuals:



# INDEX

<b>1. GENERAL SAFETY INSTRUCTIONS</b> .....	6
<b>2. INTRODUCTION</b> .....	7
<b>3. THE ATYS FAMILY PRODUCT RANGE</b> .....	8
<b>3.1. THE ATYS RANGE KEY FEATURES</b> .....	8
<b>4. QUICK START</b> .....	10
<b>4.1. QUICK START ATYS D FRAME B3 TO B5 (125A TO 630A)</b> .....	10
<b>4.1. QUICK START ATYS D FRAME B6 TO B8 (800A TO 3200A)</b> .....	12
<b>5. GENERAL OVERVIEW</b> .....	14
<b>5.1. PRODUCT INTRODUCTION</b> .....	14
<b>5.2. PRODUCT IDENTIFICATION</b> .....	15
<b>5.3. ENVIRONMENTAL</b> .....	16
<b>5.3.1. IP RATING</b> .....	16
<b>5.3.2. OPERATING CONDITIONS</b> .....	16
<b>5.3.2.1. TEMPERATURE</b> .....	16
<b>5.3.2.2. HYGROMETRY</b> .....	16
<b>5.3.2.3. ALTITUDE</b> .....	16
<b>5.3.3. STORAGE CONDITIONS</b> .....	16
<b>5.3.3.1. TEMPERATURE</b> .....	16
<b>5.3.3.2. STORAGE DURATION PERIOD</b> .....	17
<b>5.3.3.3. STORAGE POSITION</b> .....	17
<b>5.3.4. VOLUME AND SHIPPING WEIGHTS BY REFERENCE ATYS D</b> .....	17
<b>5.3.5. CE MARKING</b> .....	18
<b>5.3.6. LEAD FREE PROCESS</b> .....	18
<b>5.3.7. WEEE</b> .....	18
<b>5.3.8. EMC STANDARD</b> .....	18
<b>5.4. ATYS D ACCESSORIES AVAILABLE</b> .....	19
<b>5.4.1. CUSTOMER MOUNTED ACCESSORIES</b> .....	19
<b>5.4.2. FACTORY FITTED ACCESSORIES</b> .....	19
<b>6. INSTALLATION</b> .....	20
<b>6.1. PRODUCT DIMENSIONS</b> .....	20
<b>6.1.1. DIMENSIONS: FRAME B3 TO B5 (125A TO 630A)</b> .....	20
<b>6.1.2. DIMENSIONS: FRAME B6 &amp; B7 (800A TO 1600A)</b> .....	21
<b>6.1.3. DIMENSIONS: FRAME B8 (2000A TO 3200A)</b> .....	22
<b>6.2. MOUNTING ORIENTATION</b> .....	23
<b>6.3. ASSEMBLY OF CUSTOMER MOUNTED ACCESSORIES</b> .....	23

6.3.1. BRIDGING BAR INSTALLATION .....	23
6.3.2. COPPER BAR CONNECTION KITS (2000A TO 3200A : FRAME B8) .....	24
6.3.3. INCOMING COPPER BAR CONNECTION KIT ASSEMBLY .....	25
6.3.4. OUTGOING BRIDGE CONNECTION ASSEMBLY .....	25
6.3.5. TERMINAL SHROUDS .....	26
6.3.6. TERMINAL SCREENS .....	26
6.3.7. EXTERNAL POWER SUPPLY (400VAC - 230VAC) .....	27
6.3.8. RAISED MOUNTING SPACERS .....	27
<b>6.4. FACTORY FITTED ACCESSORIES .....</b>	<b>28</b>
6.4.1. PADLOCKING KEY INTERLOCKS .....	28
6.4.2. ADDITIONAL AUXILIARY CONTACTS .....	28
<b>7. CONNECTIONS .....</b>	<b>29</b>
<b>7.1. POWER CIRCUITS .....</b>	<b>29</b>
7.1.1. CABLE OR BAR CONNECTIONS .....	29
7.1.2. POWER CONNECTION TERMINALS .....	29
7.1.3. POWER CONNECTION CROSS-SECTION .....	29
<b>7.2. CONTROL CIRCUITS .....</b>	<b>30</b>
7.2.1. TYPICAL ATYS D WIRING .....	30
7.2.2. ATYS D INPUT AND OUTPUT CONTACTS .....	31
7.2.2.1. TERMINAL DENOMINATION, DESCRIPTION AND CHARACTERISTICS .....	31
7.2.3. ATYS D RTSE + ATS CONTROLLERS TYPE ATYS C30 AND ATYS C40 .....	32
<b>8. ATYS D OPERATING MODES .....</b>	<b>33</b>
<b>8.1. MANUAL OPERATION .....</b>	<b>34</b>
8.1.1. EMERGENCY MANUAL OPERATION .....	34
8.1.2. PADLOCKING .....	34
<b>8.2. ELECTRICAL OPERATION .....</b>	<b>35</b>
8.2.1. POWER SUPPLY .....	35
8.2.2. FIXED INPUTS .....	35
8.2.2.1. DESCRIPTION .....	35
8.2.2.2. TECHNICAL DATA .....	36
8.2.2.3. REMOTE CONTROL LOGIC .....	36
8.2.3. FIXED OUTPUTS - DRY CONTACTS .....	37
8.2.3.1. DESCRIPTION .....	37
8.2.3.2. POSITION AUXILIARY CONTACT .....	37
8.2.3.3. ATYS D PRODUCT AVAILABLE OUTPUT (MOTORISATION) .....	37
8.2.3.4. TECHNICAL DATA .....	38
<b>9. CHARACTERISTICS .....</b>	<b>39</b>
<b>10. PREVENTIVE MAINTENANCE .....</b>	<b>42</b>
<b>11. TROUBLE SHOOTING GUIDE .....</b>	<b>42</b>
<b>12. ACCESSORIES: ORDERING INFORMATION .....</b>	<b>43</b>
12.1. TERMINAL SHROUDS .....	43

12.2. TERMINAL SCREENS .....	.43
12.3. BRIDGING BARS .....	.43
12.4. POWER TERMINAL CONNECTION KITS .....	.44
12.5. CONTROL VOLTAGE TRANSFORMER .....	.44
12.6. PHASE FAILURE DEVICE .....	.45
12.7. DOOR ESCUTCHEON PLATE .....	.45
12.8. MOUNTING SPACERS .....	.45
12.9. ATYS C30 / C40 ATS CONTROLLERS .....	.45
12.10. REMOTE DISPLAY AND CONTROL UNITS .....	.46
12.11. COMMUNICATION CABLE .....	.46
12.12. DC POWER SUPPLY .....	.46
<b>13. FACTORY FITTED ACCESSORIES .....</b>	<b>.47</b>
13.1. ADDITIONAL AUXILIARY CONTACTS .....	.47
13.2. PADLOCKING IN ALL 3 POSITIONS I – 0 - II .....	.47
13.3. PADLOCKING WITH RONIS TYPE ACCESSORIES .....	.47
<b>14. ATYS FAMILY: ORDERING INFORMATION .....</b>	<b>.48</b>

# 1. GENERAL SAFETY INSTRUCTIONS

- This manual provides instructions on safety, connections and operation of the ATyS d motorised changeover switch manufactured by SOCOMEC.
- Whether the ATyS d is sold as a loose product, as a spare, as an enclosed solution or as any other configuration, this device must always be installed and commissioned by qualified and experienced personnel, in line with the manufacturers recommendations, following good engineering practices and after having read and understood the details in the latest release of the relative product instruction manual.
- Maintenance on the product and any other associated equipment including but not limited to servicing operations must be performed by adequately trained and qualified personnel.
- Each product is shipped with a label or other form of marking including rating and other important specific product information. One must also refer to and respect markings on the product prior to installation and commissioning for values and limits specific to that product.
- Using the product outside the intended scope, outside SOCOMEC recommendations or outside the specified ratings and limits can cause personal injury and/or damage to equipment.
- This instruction manual must be made accessible so as to be easily available to anyone who may need to read it in relation with the ATyS d.
- The ATyS d meets the European Directives governing this type of product and includes CE marking on each product.
- No covers on the ATyS d should be opened (with or without voltage) as there may still be dangerous voltages inside the product such as those from external circuits.
- **Do not handle any control or power cables connected to the ATyS d when voltage may be present on the product directly through the mains or indirectly through external circuits.**
- Voltages associated with this product may cause injury, electric shock, burns or death. Prior to carry out any maintenance or other work on live parts or other parts in the vicinity of exposed live parts, ensure that the switch including all control and associated circuits are de-energized.

 <b>DANGER</b>	 <b>WARNING</b>	 <b>CAUTION</b>
<b>RISK:</b> Electric shock, burns, death	<b>RISK:</b> Possible personal injury	<b>RISK:</b> Equipment damage

- As a minimum the ATyS d comply with the following international standards:
  - IEC 60947-6-1
  - GB 14048-11
  - EN 60947-6-1
  - VDE 0660-107
  - BS EN 60947-6-1
  - NBN EN 60947-6-1
  - IEC 60947-3
  - IS 13947-3
  - EN 60947-3
  - NBN EN 60947-3
  - BS EN 60947-3

The information provided in this instruction manual is subject to change without notice, remains for general information only and is non-contractual.

## 2. INTRODUCTION

ATyS d “remotely operated transfer switching equipment” (RTSE) is designed for use in power systems for the safe transfer of a load supply between a normal and an alternate source. The changeover is done in open transition and with minimum supply interruption during transfer ensuring full compliance with IEC 60947-6-1, GB 14048-11 and other international TSE standards as listed.

The ATyS d is a full load break (switch type) derived transfer switching equipment where the main components are proven technology devices also fulfilling requirements in IEC 60947-3 standards.

As a Class PC RTSE, the ATyS d is capable of “making and withstanding short circuit currents” assigned to IEC 60947-3 utilization categories of up to AC23A, GB 14048-11, IEC 60947-6-1 and equivalent standards with utilization categories of to AC33B.

### ATyS d motorised source changeover switches ensure:

- Power Control and Safety between a normal and an alternate source.
  - A complete product delivered as a fully assembled and tested solution.
  - Intuitive HMI for emergency / local operation.
  - Integrated and robust switch disconnection.
  - Window with clearly visible position indication I – 0 - II .
  - An inherent failsafe mechanical interlock.
  - Stable positions (I – 0 – II) non affected by typical vibration and shocks.
  - Constant pressure on the contacts non effected by network voltage.
  - Energy Efficient with virtually no consumption whilst on the normal, alternate or off positions.
  - Quick, easy and safe dual “on-load” emergency manual operation.  
(Manual operation is functional with and without the motorization in place).
  - Extremely rugged, error free and built in padlocking facility.
  - Straight forward installation with effective ergonomics.
  - Minimal downtime with the possibility to perform easy maintenance.
  - Simple and secure motorization controls interface.
  - Integrated switch position auxiliary contacts.
  - An active “product availability” status feedback.
  - Ample accessories to suit specific requirements.
  - Compatibility with virtually any make of ATS, AMF, Genset controller.  
(Typically an ATyS C30 / C40 ATS Controller and driven through volt free contacts)
- Power supply continuity for most applications.

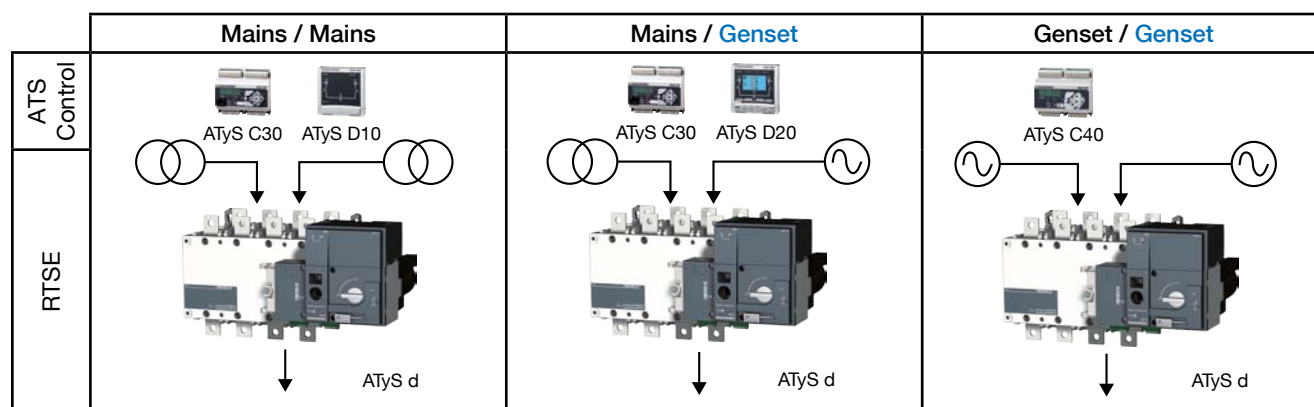

### 3. THE ATyS FAMILY PRODUCT RANGE

The ATyS d has been engineered by the SOCOMEC centre of excellence in France who boasts it's very own in-house 100MVA instantaneous power test lab accredited by COFRAC and working in partnership with: KEMA, CEPEC, UL, CSA, ASTA, Lloyd's Register of Shipping, Bureau Veritas, BBJ-SEP, EZU, GOST-R... and others.

SOCOMEC has been manufacturing power control and safety products since 1922. The first generation SOCOMEC "motorised changeover switches" were introduced in 1990 and today the ATyS brand has become trusted by major players in the power industry worldwide.

The ATyS Family includes a complete range of remotely operated transfer switch equipment (RTSE) as well as automatic fully integrated products and solutions (ATSE). Selecting the right ATyS will depend on the application as well as the nature of installation in which the ATyS will be installed.

This instruction manual includes details and instructions specific to the "ATyS d" RTSE only. For all other ATyS family of products please refer to the specific instruction manual related to that product.

(Available for download on [www.socomec.com](http://www.socomec.com))

**An overview of the complete ATyS range is presented below:**

*(The encircled device is the product detailed in this instruction manual).*

**Just the right ATyS for your application...**

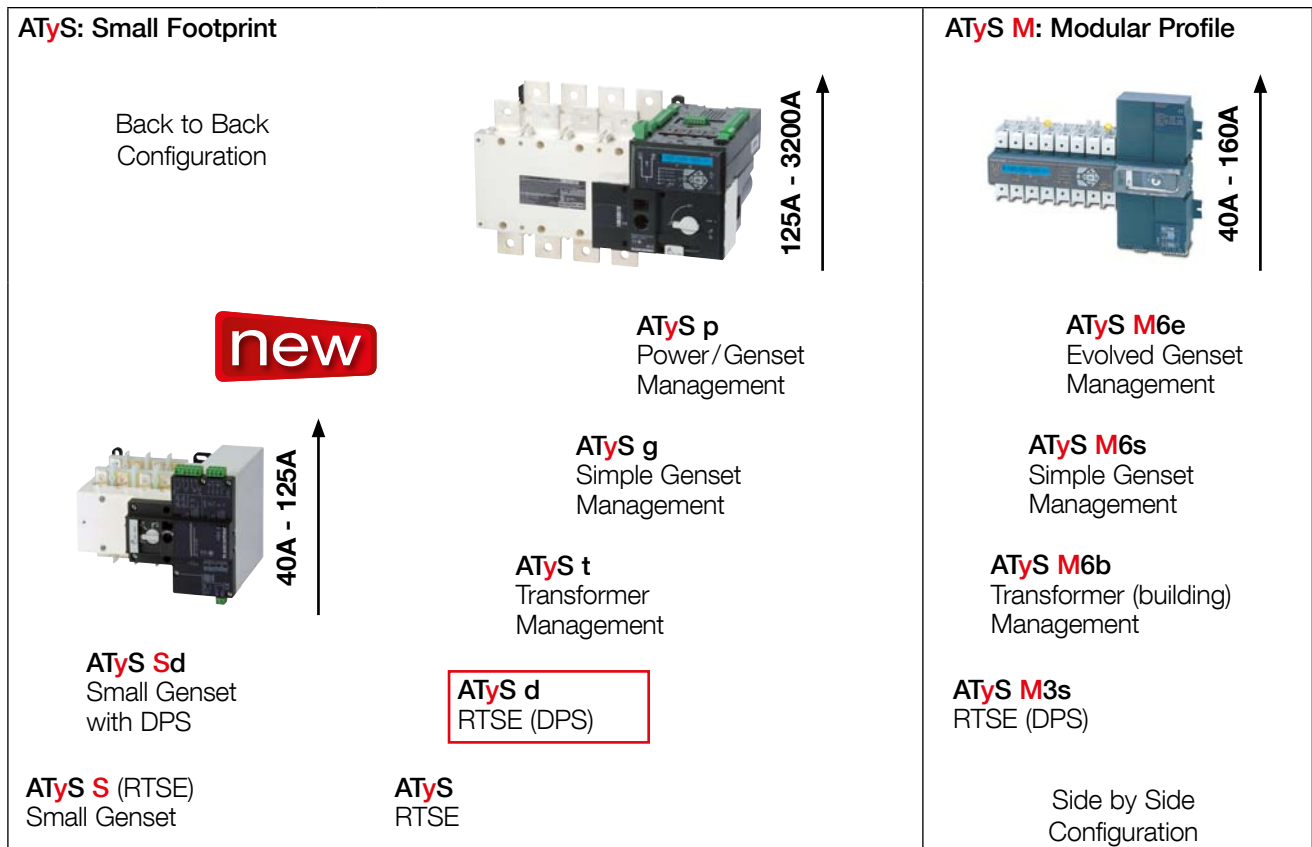

#### 3.1. The ATyS Range Key Features

Selecting the right ATyS will depend on the application, the functionality required as well as the nature of the installation in which the ATyS will be installed. Below is an outline product selection chart listing the key features of each product to help to select the right ATyS for your needs.



	ATyS S	ATyS Sd	ATyS	ATyS d	ATyS t	ATyS g	ATyS p
Motorised Changeover with control driven by dry contacts	•	•	•	•	•	•	•
Manual Emergency Operation with external handle	•	•	•	•	•	•	•
Wide band AC control voltage supply	•	•	•	•	•	•	•
Wide band DC control voltage supply	•						
Watchdog relay to ensure product availability			•	•	•	•	•
Ratings from 40 – 125A as indicated or 125A - 3200A for •	40 – 125A	40 – 125A	•	•	•	•	•
Override controls and force switch to zero (off) position			•	•	•	•	•
Integrated position auxiliary contacts (I - O - II)	•	•	•	•	•	•	•
Source availability LED display				•	•	•	•
Remote Display module RJ45 connection for ATyS D10				•	•	•	
Integrated Dual power supply		•		•	•	•	•
Network - Network Applications	•	•	•	•	•		•
Network - Genset Applications	•	•	•	•		•	•
Genset - Genset Applications	•	•	•	•			
Pre-defined fixed I/O			• 5/1	• 5/1	• 9/2	• 11/3	• 5/2
Programmable I/O							• 6/1
Additional programmable I/O modules (Optional up to 4 modules)							• 8/8
Remotely operated Transfer Switching Equipment (RTSE Class PC)	•	•	•	•			
Automatic Transfer Switching Equipment (ATSE Class PC)					•	•	•
Remote + Manual Control	•	•	•	•			
Auto + Remote + Manual Control					•	•	
Auto + Remote + Local + Manual Control							•
Auto-configuration of voltage and frequency levels					•	•	•
Switch Position LED display					•	•	•
Security Sealing Cover					•	•	
Configuration through potentiometers and dip switches					•	•	
Test on load functionality						•	•
Test off load functionality						•	•
Programmable configuration with keypad and LCD display							•
Metering & Measurement: kW; kVar; kVA + kWh; kVarh; kVAh							•
Communication RS485 + Ethernet + Ethernet gateway (Optional)							•
Webserver Access through optional Ethernet module (Optional)							•
Easy Configuration software (Through Ethernet/Modbus)							•
Remote Terminal Unit RJ45 connection for ATyS D20							•
Data Logger for Event Recording with RTC (Through Ethernet/Modbus)							•
Programmable Engine Exerciser functionality (Through Ethernet/Modbus)							•
Multi level password access							•
Load Shedding function							•
Capacity Management functionality							•
Peak shaving functionality							•
4 - 20mA communication module (Optional)							•
KWh Pulsed output module (Optional)							•
Counters KWh, permutation...							•
LCD display for programming, metering, timers and counters							•
Possibility to add optional functionality							•

# 4. QUICK START

## 4.1. Quick Start ATyS d Frame B3 to B5 (125A to 630A)



QUICK START EN 125A - 630A

# ATyS d

Motorised Source Changeover Switch

### Preliminary operations

Check the following upon delivery and after removal of the packaging:

- Packaging and contents are in good condition.
- The product reference corresponds to the order.
- Contents should include:
  - Qty 1 x ATyS d
  - Qty 1 x Emergency handle and fixing clip
  - Quick Start instruction sheet

### Warning

**⚠ Risk of electrocution, burns or injury to persons and / or damage to equipment.**

This Quick Start is intended for personnel trained in the installation and commissioning of this product. For further details refer to the product instruction manual available on the SOCOMEC website.

- This product must always be installed and commissioned by qualified and approved personnel.
- Maintenance and servicing operations should be performed by trained and authorised personnel.
- Do not handle any control or power cables connected to the product when voltage may be, or may become present on the product, directly through the mains or indirectly through external circuits.
- Always use an appropriate voltage detection device to confirm the absence of voltage.
- Ensure that no metal objects are allowed to fall in the cabinet (risk of electrical arcing).

Failure to observe good engineering practises as well as to follow these safety instructions may expose the user and others to serious injury or death.

**⚠ Risk of damaging the device**

- In case the product is dropped or damaged in any way it is recommended to replace the complete product.

### Accessories

- Bridging bars and connection kits.
- Control voltage transformer (400Vac -> 230Vac).
- DC power supply (12/24Vdc -> 230Vac).
- Mounting spacers to raise the product x 10mm.
- Phase barriers.
- Terminal shrouds.
- Terminal screens.
- Auxiliary contacts (Additional).
- Padlocking in 3 positions (I - 0 - II).
- Lockout accessories (RONIS - EL II AP).
- Door escutcheon frame.
- Control relay ATyS C30 + D10 or D20.
- Control relay ATyS C40.
- ATyS D10 Interface (remote display).

For further details refer to the product instruction manual under chapter "Spares and Accessories"

www.socomec.com

To download, brochures, catalogues and technical manuals:



Printing informations: 1 color Black. White paper 90g/m<sup>2</sup>.  
Printing size: 420x297. Final size 210x297. This page visible first.



541 988 B - 09/13 - EN



Non contractual document.  
Subject to change without notice.

### Installation and Commissioning

**STEP 1**  
Cabinet / Back Plate Installation

**STEP 2**  
Connecting the POWER section

**STEP 3**  
COMMAND / CONTROL terminal connections

**STEP 4**  
Power SUPPLY terminal connections

**STEP 5**  
CHECK

**STEP 6A**  
Control by an external order (AUTO)

**STEP 6B**  
Emergency Manual Operation

**STEP 6C**  
Padlocking

**STEP 6B Manual Operation**

90°     90°     AUT

AUT

✘

✘

**STEP 6C Padlocking Mode (as standard: in position 0)**

AUT

✘

✘

**STEP 5**

**Check**

Whilst in manual mode, check the wiring and if ok power up the product.

LED "Power" Green: ON  
LED "Source" Green: ON  
(I) / (II) or (I) (II)  
LED Manual/Default Red (Product not Available): ON

**STEP 6A Automatic Operation**

Ensure that the emergency handle is not inserted in the product and turn the mode selector to the AUT position.  
LED "Power" Green: ON  
LED Manual/Default: OFF

Impulse logic

Contactor logic

Imp. ≥60ms     maintained

To enable control, close contact 312 with 317.  
To force the product to 0 position/OFF bridge the contact 313 with 317.  
For contactor logic bridge contact 316 with 317.  
To operate: close the contact corresponding to the desired position.

### STEP 1 Installation

Attention: Ensure that the product is installed on a flat rigid surface.  
Orientation:

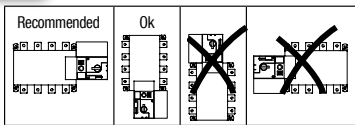

Door cut-out for front panel.

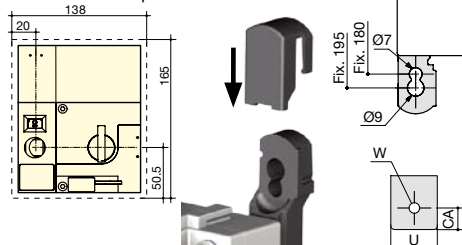

Dimensions in mm.

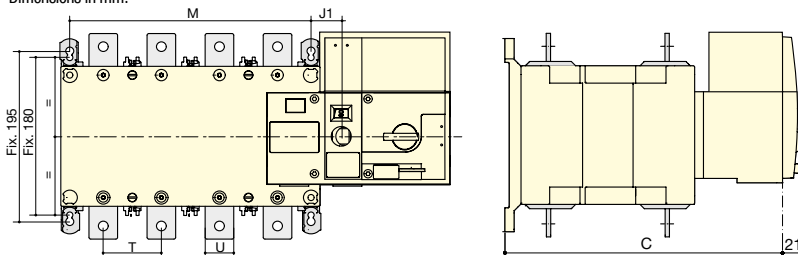

	125 A		160 A		200 A		250 A		315 A		400 A		500 A		630 A	
	3 P	4 P	3 P	4 P	3 P	4 P	3 P	4 P	3 P	4 P	3 P	4 P	3 P	4 P	3 P	4 P
J 1	34	34	34	34	34	34	35	35	35	35	35	35	34	34	34	34
M	120	150	120	150	120	150	160	210	160	210	160	210	210	270	210	270
T	36	36	36	36	36	36	50	50	50	50	50	50	65	65	65	65
C	244	244	244	244	244	244	244	244	244	244	244	244	320	320	320	320
U	20	20	20	20	20	20	25	25	25	25	35	35	32	32	45	45
W	9	9	9	9	9	9	9	11	11	11	11	11	13	13	13	13
CA	10	10	10	10	10	10	15	15	15	15	15	15	20	20	20	20

### STEP 2 Power Terminal Connections

To be connected using terminal lugs, rigid or flexible busbars.

	FRAME B3			FRAME B4			FRAME B5	
	125 A	160 A	200 A	250 A	315 A	400 A	500 A	630 A
Minimum cable section Cu (mm <sup>2</sup> ) at lth	50	70	95	120	185	240	2x150	2x185
Minimum cable section Cu (mm <sup>2</sup> ) at lth	-	-	-	-	-	-	2x30x5	2x40x5
Maximum cable section Cu (mm <sup>2</sup> )	50	95	150	150	240	240	2x300	2x300
Maximum Cu busbar width (mm)	20	20	32	32	32	32	50	50
Type of screw	M8	M8	M8	M10	M10	M10	M12	M12
Recommended tightening torque (N.m)	8.3	8.3	8.3	20	20	20	40	40
Maximum tightening torque (N.m)	13	13	13	26	26	26	45	45

### STEP 3 CONTROL / COMMAND Terminals - Ensure that the product is in Manual Mode.

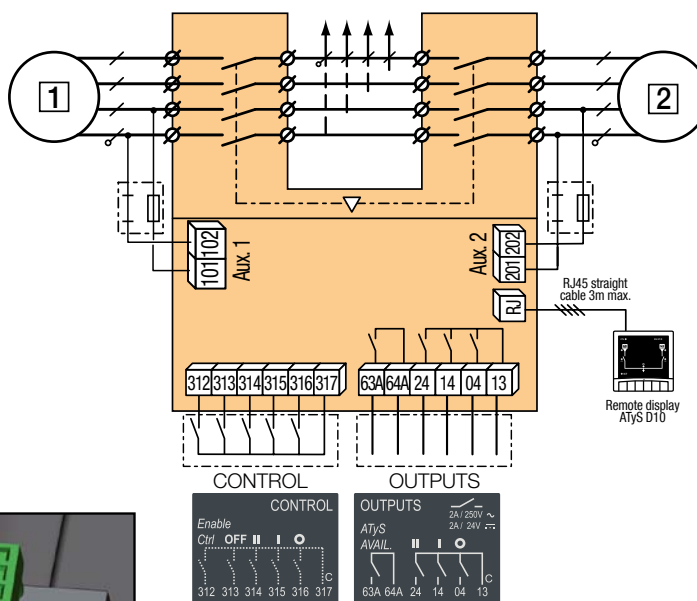
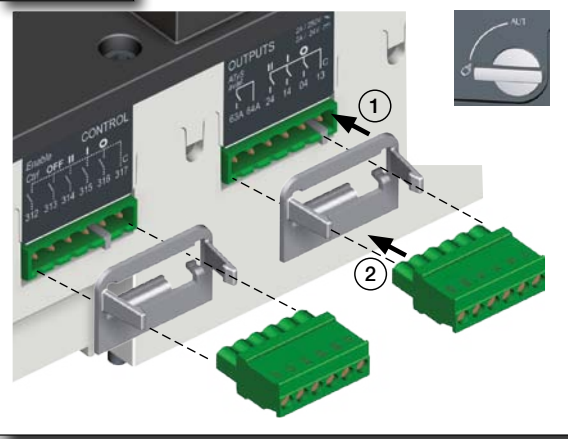

### STEP 4 Dual Power Supply Terminals



Connect the product with a cable of section of 1,5 to 2,5 mm<sup>2</sup>.  
Screw M3 - Tightening torque: min.: 0.5 Nm - max.: 0.6 Nm

# 4.1. Quick Start ATyS d Frame B6 to B8 (800A to 3200A)



QUICK START EN 800A - 3200A

## ATyS d

Motorised Source Changeover Switch

### Preliminary operations

Check the following upon delivery and after removal of the packaging:

- Packaging and contents are in good condition.
- The product reference corresponds to the order.
- Contents should include:
  - Qty 1 x ATyS d
  - Qty 1 x Emergency handle and fixing clip
  - Quick Start instruction sheet

### Warning

**⚠ Risk of electrocution, burns or injury to persons and / or damage to equipment.**

This Quick Start is intended for personnel trained in the installation and commissioning of this product. For further details refer to the product instruction manual available on the SOCOMEC website.

- This product must always be installed and commissioned by qualified and approved personnel.
- Maintenance and servicing operations should be performed by trained and authorised personnel.
- Do not handle any control or power cables connected to the product when voltage may be, or may become present on the product, directly through the mains or indirectly through external circuits.
- Always use an appropriate voltage detection device to confirm the absence of voltage.
- Ensure that no metal objects are allowed to fall in the cabinet (risk of electrical arcing).

Failure to observe good engineering practises as well as to follow these safety instructions may expose the user and others to serious injury or death.

**⚠ Risk of damaging the device**

- In case the product is dropped or damaged in any way it is recommended to replace the complete product.

### Accessories

- Bridging bars and connection kits.
- Control voltage transformer (400Vac -> 230Vac).
- DC power supply (12/24Vdc -> 230Vac).
- Mounting spacers to raise the product x 10mm.
- Phase barriers.
- Terminal shrouds.
- Terminal screens.
- Auxiliary contacts (Additional).
- Padlocking in 3 positions (I - 0 - II).
- Lockout accessories (RONIS - EL II AP).
- Door escutcheon frame.
- Control relay ATyS C30 + D10 or D20.
- Control relay ATyS C40.
- ATyS D10 Interface (remote display).

For further details refer to the product instruction manual under chapter "Spares and Accessories"

www.socomec.com

To download, brochures, catalogues and technical manuals:



Printing informations: 1 color Black. White paper 90g/m<sup>2</sup>.  
Printing size: 420x297. Final size 210x297. This page visible first.



541 989 C - 09/13 - EN



Non contractual document.  
Subject to change without notice.

### Installation and Commissioning

**STEP 1**  
Cabinet / Back Plate Installation

**STEP 2**  
Connecting the POWER section

**STEP 3**  
COMMAND / CONTROL terminal connections

**STEP 4**  
Power SUPPLY terminal connections

**STEP 5**  
CHECK

**STEP 6A**  
Control by an external order (AUTO)

**STEP 6B**  
Emergency Manual Operation

**STEP 6C**  
Padlocking

**STEP 6B Manual Operation**

**STEP 5 Check**

Whilst in manual mode, check the wiring and if ok power up the product.

LED "Power" Green: ON  
LED "Source" Green: ON  
(I) / (II) or (I) (II)  
LED Manual/Default Red (Product not Available): ON

**STEP 6A Automatic Operation**

Ensure that the emergency handle is not inserted in the product and turn the mode selector to the AUT position.  
LED "Power" Green: ON  
LED Manual/Default: OFF

Impulse logic

Contactor logic

■ Imp. ≥60ms      ■ maintained

To enable control, close contact 312 with 317.  
To force the product to 0 position/OFF bridge the contact 313 with 317.  
For contactor logic bridge contact 316 with 317.  
To operate: close the contact corresponding to the desired position.

**STEP 6C Padlocking Mode (as standard: in position 0)**

**STEP 1**

**Installation**

Attention: Ensure that the product is installed on a flat rigid surface. Orientation:

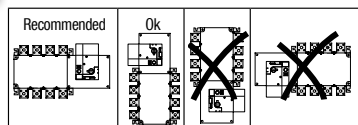

Door cut-out for front panel.

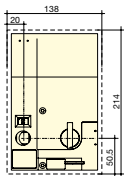

ATyS 800 to 1000 A

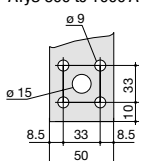

ATyS 1250 A

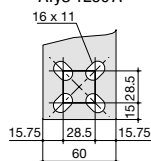

ATyS 1600 to 3200 A

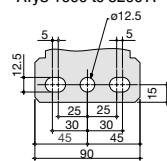

Dimensions in mm.

	800 A		1000 A		1250 A		1600 A		2000 A		2500 A		3200 A	
	3 P	4 P	3 P	4 P	3 P	4 P	3 P	4 P	3 P	4 P	3 P	4 P	3 P	4 P
M	255	335	255	335	255	335	347	467	347	467	347	467	347	467
T	80	80	80	80	80	80	120	120	120	120	120	120	120	120
C	391	391	391	391	391	391	391	391	523	523	523	523	523	523

**STEP 2**

**Power Terminal Connections**

To be connected using terminal lugs, rigid or flexible busbars.

	FRAME B6			FRAME B7	FRAME B8		
	800 A	1000 A	1250 A	1600 A	2000 A	2500 A	3200 A
Minimum cable section Cu (mm <sup>2</sup> ) at lth	2x240	-	-	-	-	-	-
Minimum cable section Cu (mm <sup>2</sup> ) at lth	2x50x5	2x60x5	2x80x5	2x100x5	3x100x5	4x100x5	3x100x10
Maximum cable section Cu (mm <sup>2</sup> )	2x300	4x185	4x185	6x185	-	-	-
Maximum Cu busbar width (mm)	63	63	63	100	100	100	100
Type of screw	M8	M8	M10	M12	M12	M12	M12
Recommended tightening torque (N.m)	8.3	8.3	20	40	40	40	40
Maximum tightening torque (N.m)	13	13	26	45	45	45	45

**STEP 3**

**CONTROL / COMMAND Terminals** - Ensure that the product is in Manual Mode.

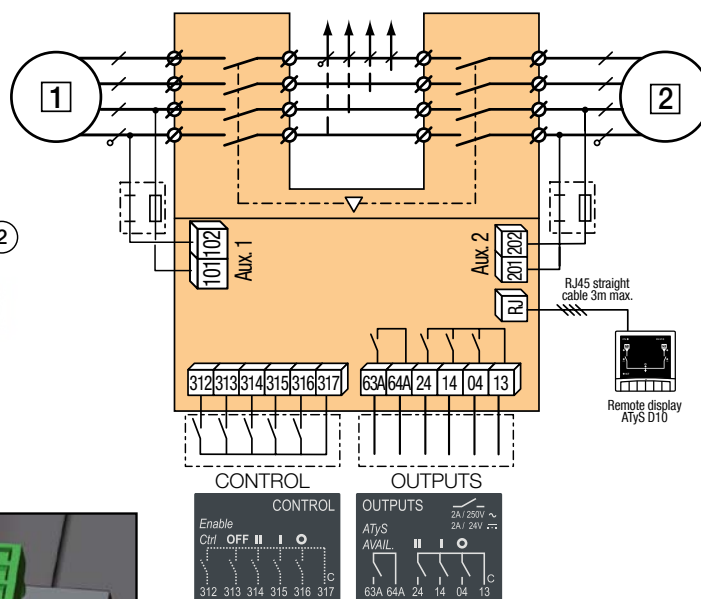
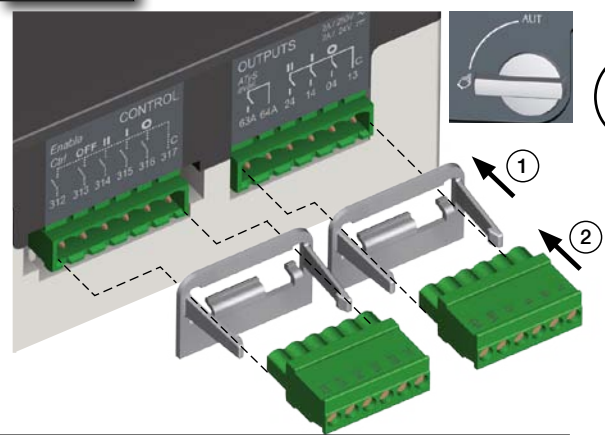

**STEP 4**

**Dual Power Supply Terminals**



Connect the product with a cable of section of 1,5 to 2,5 mm<sup>2</sup>.  
Screw M3 - Tightening torque: min.: 0.5 Nm - max.: 0.6 Nm

# 5. GENERAL OVERVIEW

## 5.1. Product introduction

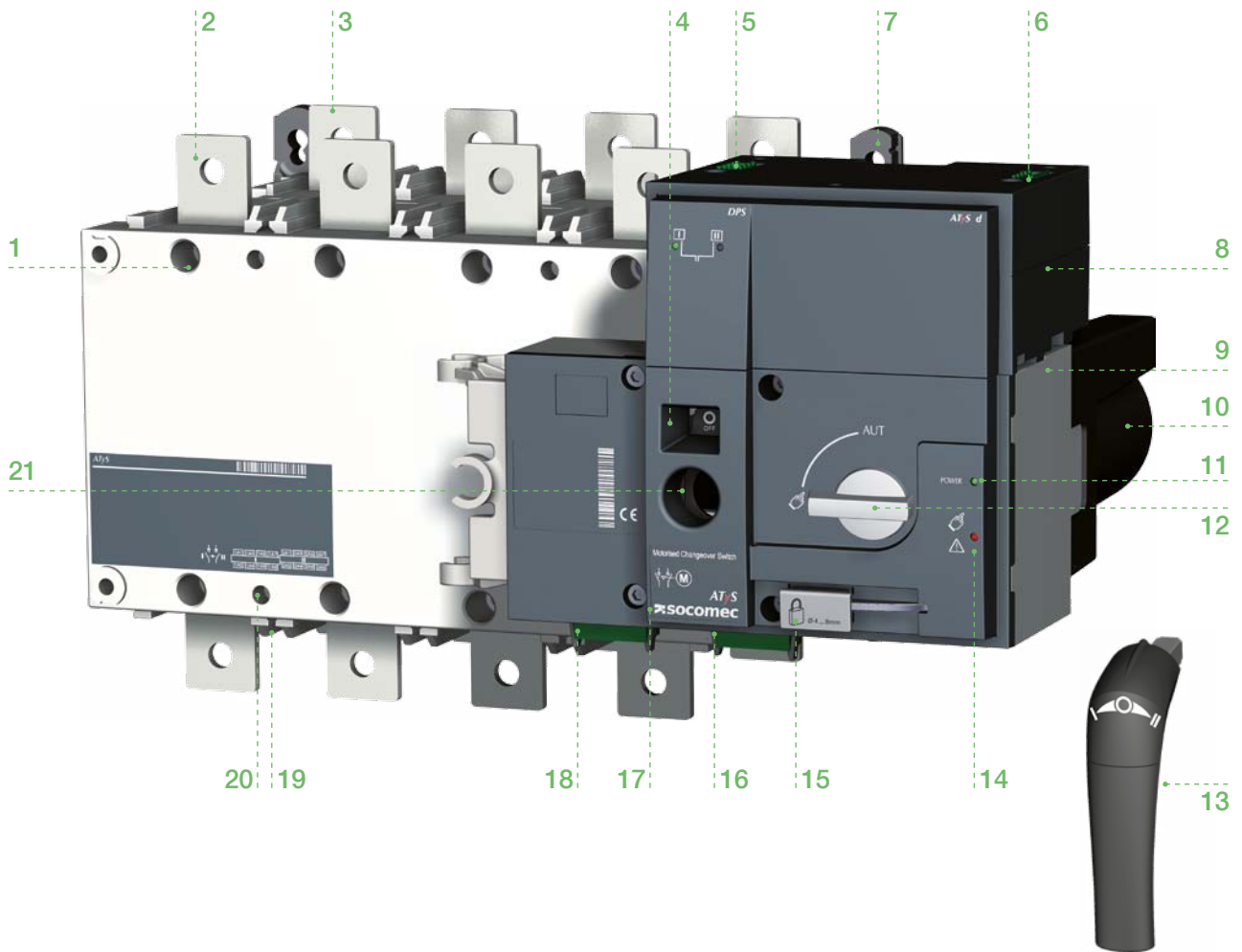

1. Power Section : Changeover switch assembly with inherent mechanical interlock
2. Front : Switch number 1 terminals (3 or 4 pole)
3. Back : Switch number 2 terminals (3 or 4 pole)
4. Switch position indication window :- I (On) – O (Off) – II (On)
5. Auxiliary power supply 1 : 230Vac (208 – 277Vac ± 20%)
6. Auxiliary power supply 2 : 230Vac (208 – 277Vac ± 20%)
7. Back-plate mounting ATyS d fixing lugs
8. Dual power supply Module
9. Motorized Control Unit
10. Motor housing
11. Green LED Indication : Power
12. Auto / Manual mode selector switch
13. Emergency manual operation “Direct Handle”
14. Red LED Indication : Product Unavailable / Manual Mode / Fault Condition
15. Padlocking facility (Up to 3 padlocks of dia. 4 – 8mm)
16. Output contacts x 4 (Position indication I-O-II and product availability outputs)
17. Facility for locking all controls in the zero position using a RONIS EL11AP Lock
18. Input contacts x 5 :-  
 Position order I-O-II  
 Remote control enable  
 Override controls and force to Off position
19. Sliders for Terminal Shields
20. Fixing holes for terminal Shields
21. Emergency manual operation shaft location (Accessible only in manual mode)

## 5.2. Product identification

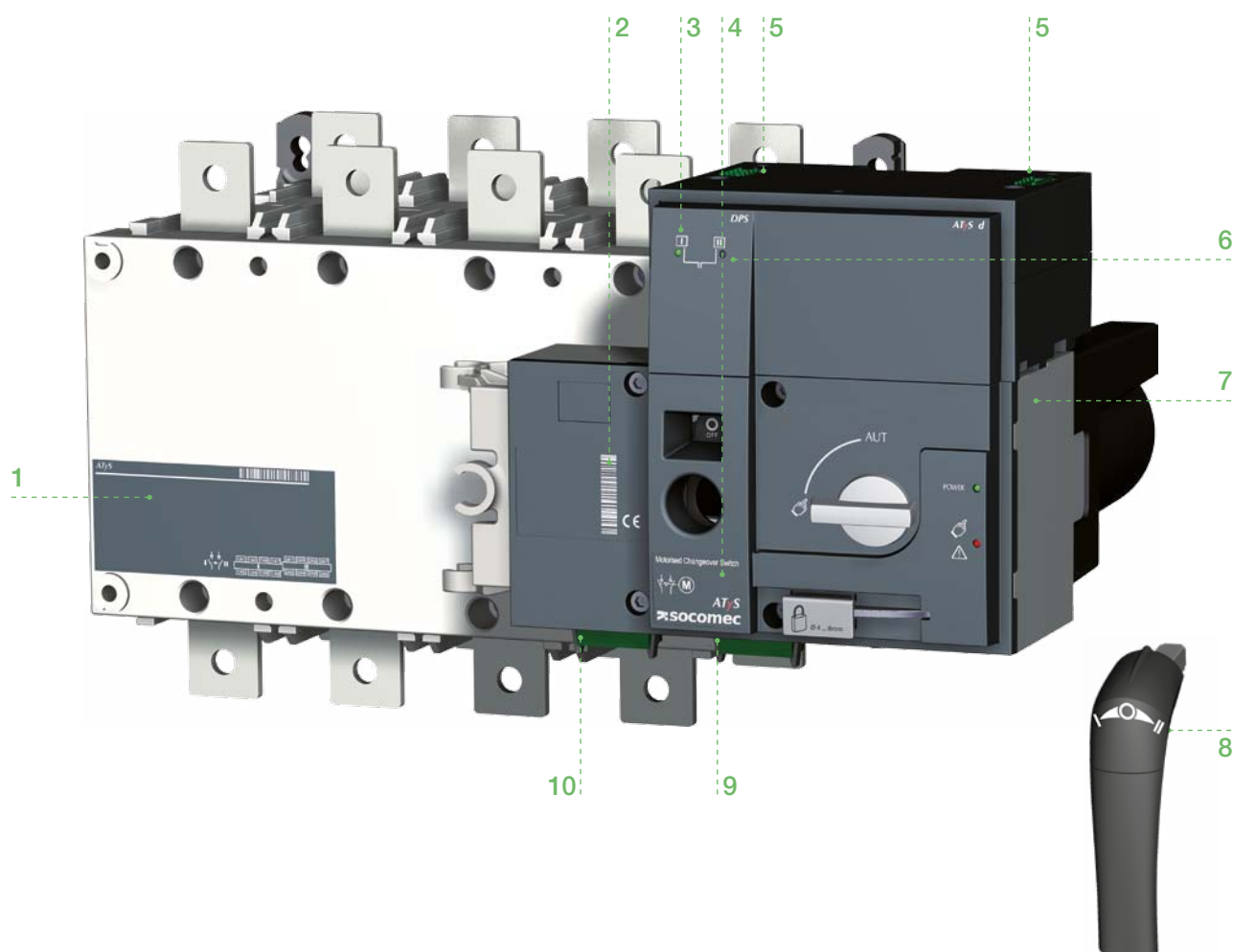

1. Main changeover switch identification label:  
Electrical characteristics  
Applicable standards and  
Terminal incoming and outgoing wiring details.
2. Complete ATyS d product serial number, barcode and CE marking.
3. Switch 1 (Front) and Switch 2 (back) identification labels
4. ATyS d product current rating and reference number label
5. Auxiliary power supply contacts identification label
6. Auxiliary power supply available LED'S
7. Motor barcode and serial number
8. Emergency manual operation direction of rotation indication
9. Output contacts identification label.
10. Input contacts identification label.

## 5.3. Environmental

The ATyS d product meets the following environmental requirements:

### 5.3.1. IP Rating



- IP2X against direct contact for the ATyS d motorization control unit.
- IP2X against direct contact for the power section with the connections in place and when including suitable, correctly installed incoming and outgoing terminal shields.
- IP 0 for the bare power section without terminal shields in place.

### 5.3.2. Operating Conditions

#### 5.3.2.1. Temperature

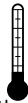

- From -20 to +40°C without derating
- From -20 to +70°C when applying a Kt derating correction factor

Kt: Correction Factor	Temperature
0.9	40 °C to 50 °C
0.8	50 °C to 60 °C
0.7	60 °C to 70 °C

\* Simplified derating method:  $I_{thu} \leq I_{th} \times K_f$

\* A more precise calculation may be done for specific applications. Should this be required please contact SOCOMEC.

#### 5.3.2.2. Hygrometry



- 80% humidity without condensation at 55°C
- 95% humidity without condensation at 40°C

#### 5.3.2.3. Altitude



- Up to 2000m in altitude without derating
- For higher altitude the Ka correction factors below apply

Ka: Correction Factor	2000 m < A ≤ 3000 m	3000 m < A ≤ 4000 m
Ue	0.95	0.8
Ie	0.85	0.85

### 5.3.3. Storage Conditions



#### 5.3.3.1. Temperature



- From -40 to +70°C



### 5.3.3.2. Storage duration period

- Maximum storage up to a period of 12 months
- (Recommendation: To be stored in dry, non corrosive and non saline atmospheric conditions)

### 5.3.3.3. Storage position

- ≤ 630 A: a maximum of 3 boxes may be stocked vertically
- ≥ 800 A: a maximum of 1 box may be stocked vertically

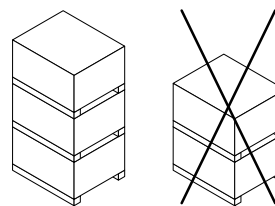

### 5.3.4. Volume and shipping weights by reference ATyS d

Frame Size	Rating	N° of Poles	Reference Number	Weight (kg)		Volume (cm) inc Packing
				Net	Gross	
B3	125A	3	95 33 <b>3 012</b>	6,3	9,6	360x480x370
		4	95 33 <b>4 012</b>	7,5	10,8	360x480x370
	160A	3	95 33 <b>3 016</b>	6,3	9,6	360x480x370
		4	95 33 <b>4 016</b>	7,5	10,8	360x480x370
	200A	3	95 33 <b>3 020</b>	6,3	9,6	360x480x370
		4	95 33 <b>4 020</b>	7,5	10,8	360x480x370
B4	250A	3	95 33 <b>3 025</b>	7,2	10,5	360x480x370
		4	95 33 <b>4 025</b>	8,0	11,3	360x480x370
	315A	3	95 33 <b>3 031</b>	7,3	10,6	360x480x370
		4	95 33 <b>4 031</b>	8,4	11,7	360x480x370
	400A	3	95 33 <b>3 040</b>	7,3	10,6	360x480x370
		4	95 33 <b>4 040</b>	8,4	11,7	360x480x370
B5	500A	3	95 33 <b>3 050</b>	12,0	15,3	536x378x427
		4	95 33 <b>4 050</b>	13,9	17,2	536x378x427
	630A	3	95 33 <b>3 063</b>	12,5	15,8	536x378x427
		4	95 33 <b>4 063</b>	14,6	17,9	536x378x427
B6	800A	3	95 33 <b>3 080</b>	28,5	44,5	730x800x600
		4	95 33 <b>4 080</b>	32,8	48,8	730x800x600
	1000A	3	95 33 <b>3 100</b>	29,0	45,0	730x800x600
		4	95 33 <b>4 100</b>	33,5	49,5	730x800x600
	1250A	3	95 33 <b>3 120</b>	29,5	45,5	730x800x600
		4	95 33 <b>4 120</b>	34,2	50,2	730x800x600
B7	1600A	3	95 33 <b>3 160</b>	33,7	49,7	730x800x600
		4	95 33 <b>4 160</b>	40,0	56,0	730x800x600
B8	2000A	3	95 33 <b>3 200</b>	51,3	67,3	730x800x600
		4	95 33 <b>4 200</b>	62,2	78,2	730x800x600
	2500A	3	95 33 <b>3 250</b>	51,3	67,3	730x800x600
		4	95 33 <b>4 250</b>	62,2	78,2	730x800x600
	3200A	3	95 33 <b>3 320</b>	61,6	77,6	730x800x600
		4	95 33 <b>4 320</b>	75,9	91,9	730x800x600

### 5.3.5. CE marking

The ATyS d complies with the European directive for:

- The Electromagnetic compatibility no. 2004/108/CE dated 15th of December 2004.
- Low voltage directive no. 2006/95/CE dated 12th of December 2006.



### 5.3.6. Lead free process

- The ATyS d complies with the European directive for RoHS.



### 5.3.7. WEEE

The ATyS d is built in accordance with 2002/96/CE directive:

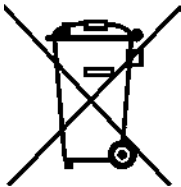

### 5.3.8. EMC standard

The ATyS d is designed and built in accordance with IEC 60947-1 standards

(Products intended to be installed in an "Industrial, Commercial and/or Residential Environment" therefore respecting both Class A as well as Class B EMC requirements).

Description	Std (IEC)	Requirement (criteria)
Conducted	CISPR 11	Class B
Radiated	CISPR 11	Class B
ESD contact	61000-4-2	4KV (B)
ESD air	61000-4-2	8KV (B)
Electromagnetic field	61000-4-3	10V/m (A)
RF Conducted	61000-4-6	10V (A)
Burst	61000-4-4	2KV (B) power 1KV (B) control
Surge differential	61000-4-5	1KV (B)
Surge Common	61000-4-5	2KV (B)

## 5.4. ATyS d ACCESSORIES AVAILABLE

### 5.4.1. Customer mounted accessories

#### BRIDGING BARS

To connect switch I & II load terminals together.

#### TERMINAL SHROUDS (125 TO 630 A)

Incoming and outgoing protection against direct contact with the connection terminals or parts. Cannot be mounted in the rear position at the same time as the voltage sensing and power outlet kit or the bridging bars.

Can be mounted top or bottom, in front or in rear position.

#### TERMINAL SCREENS

Incoming and outgoing protection against direct contact with the connection terminals or parts.

#### DOOR ESCUTCHEON PLATE

An accessory to be fixed onto a cabinet door to frame the controller part of flush mounted ATyS p transfer switches.

#### DC POWER SUPPLY (DC -> AC)

Allows a standard 230Vac ATyS d to be supplied through a DC Aux Power supply.

#### CONTROL VOLTAGE TRANSFORMER

Allows a standard 230 V AC device to be supplied with 400 VAC.

#### MOUNTING SPACERS (125 TO 630 A)

Raises the device's terminals 10 mm away from the backplate or frame

#### REMOTE INTERFACES ATyS D10

Remote Display: Allows source supply state and switch positions to be displayed remotely. (LED display)

Typically door mounted or  $\leq 3$ m away from the ATyS.

#### COMMUNICATION CABLE

RJ 45 communication cable (3m long) for use with the ATyS D10 remote display/controller or Ethernet modules.

#### Others:

Refer to the end of this instruction manual or the latest SOCOMEC product catalogue. (Downloadable from [www.socomec.com](http://www.socomec.com))

### 5.4.2. Factory fitted accessories

#### SUPPLEMENTARY AUXILIARY CONTACT (AC)

Pre-breaking and signaling of positions I and II: 1 additional auxiliary contact NO / NC auxiliary contact in each position. Included as standard for ratings from 2000 to 3200A. For Low level AC: please consult SOCOMEC.

#### KEY LOCK AUTO / MANUAL SELECTOR SWITCH

The ATyS d mode selector switch is delivered with a rotary handle as standard. This can be factory replaced with a key lock when the ATyS d is ordered accordingly. Refer to the style chart at the end of this document.

#### RONIS KEY PADLOCKING ACCESSORIES

Locking of the electrical and the manual operation by means of a RONIS EL11AP lock. Possibility of locking in another position, if the "Padlocking in the 3 positions" option is ordered.

Not compatible with flush mounting.

#### PADLOCKING IN 3 POSITIONS

Allows locking of the operation in the 3 positions I, 0 and II.

# 6. INSTALLATION

## 6.1. Product dimensions

### 6.1.1. Dimensions: Frame B3 to B5 (125A to 630A)

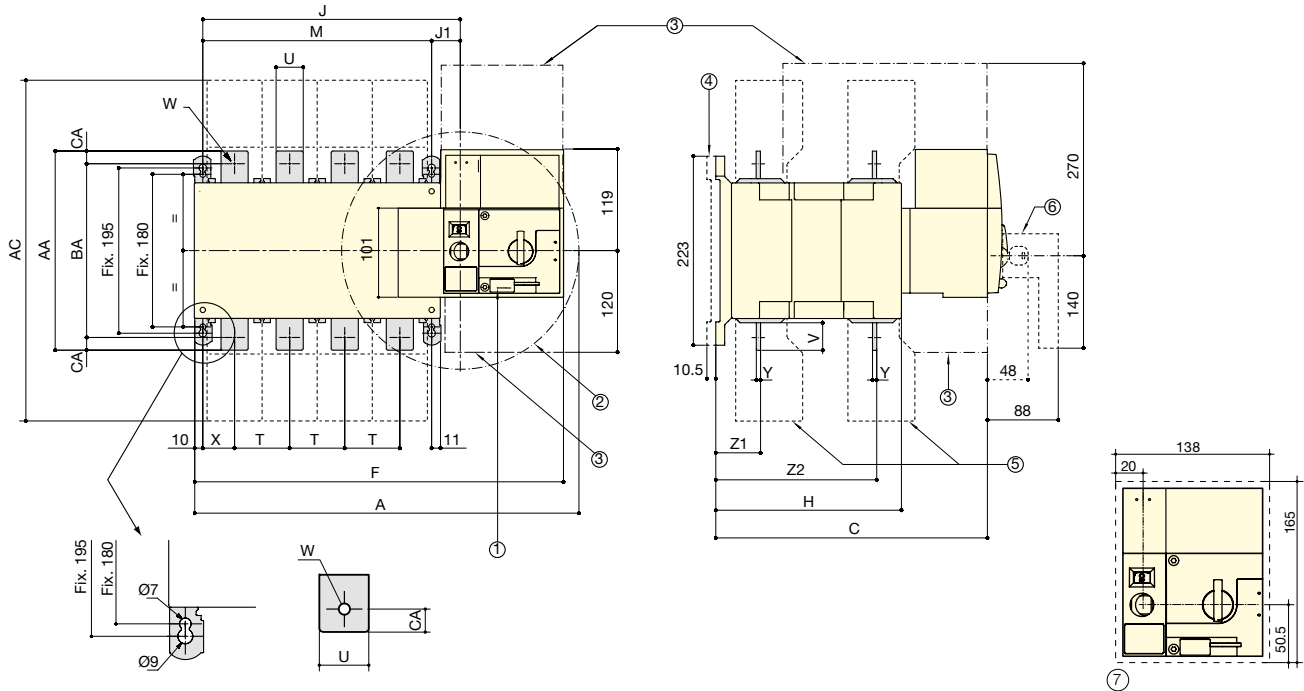

1. Padlocking Facility: Locking bracket for up to 3 padlocks of dia. 4 – 8mm
2. Emergency manual operation: Maximum operating radius with an operating angle of 2x 90°
3. Connection and disconnection area
4. Mounting stand off with spacer accessory
5. Phase Barriers
6. Emergency removable handle
7. Flush mounting cutout dimensions for front door



To consider the space required for manual operation and wiring.  
(When using the ATyS d emergency handle: note 2).

Rating (A)	Overall dimensions			Terminal shrouds AC	Body						Switch mounting		Connection											
	A 3p.	A 4p.	C		F 3p.	F 4p.	H	J 3p.	J 4p.	J1	M 3p.	M 4p.	T	U	V	W	X 3p.	X 4p.	Y	Z1	Z1	AA	BA	CA
125	304	334	244	233	286.5	317	151	154	184	34	120	150	36	20	25	9	28	22	3.5	38	134	135	115	10
160	304	334	244	233	286.5	317	151	154	184	34	120	150	36	20	25	9	28	22	3.5	38	134	135	115	10
200	304	334	244	233	286.5	317	151	154	184	34	120	150	36	20	25	9	28	22	3.5	38	134	135	115	10
250	345	395	244	288	328	378	152	195	245	35	160	210	50	25	30	11	33	33	3.5	39.5	133.5	160	130	15
315	345	395	244	288	328	378	152	195	245	35	160	210	50	25	30	11	33	33	3.5	39.5	133.5	160	130	15
400	345	395	244	288	328	378	152	195	245	35	160	210	50	35	35	11	33	33	3.5	39.5	133.5	170	140	15
500	394	454	321	402	377	437	221	244	304	34	210	270	65	45	50	13	42.5	37.5	5	53	190	260	220	20
630	394	454	321	402	377	437	221	244	304	34	210	270	65	45	50	13	42.5	37.5	5	53	190	260	220	20

All dimensions in mm

### 6.1.2. Dimensions: Frame B6 & B7 (800A to 1600A)

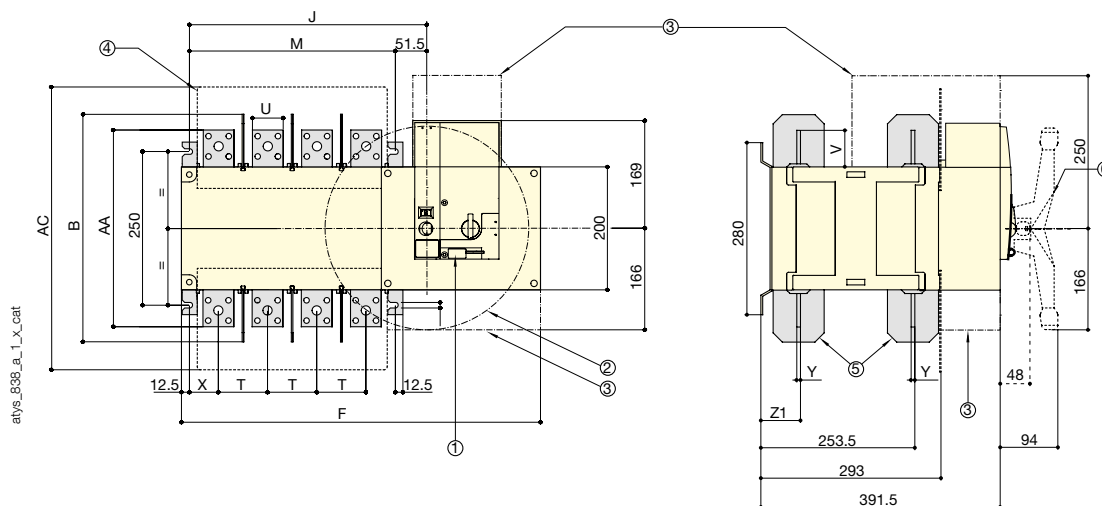

ENGLISH

800 to 1000 A

1250 A

1600 A

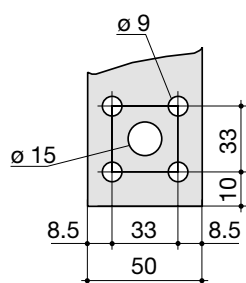

svr\_077\_a\_1\_x\_cat

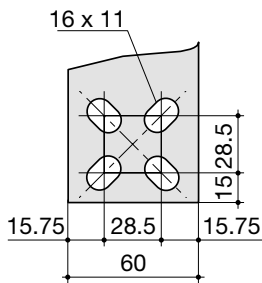

svr\_078\_b\_1\_x\_cat

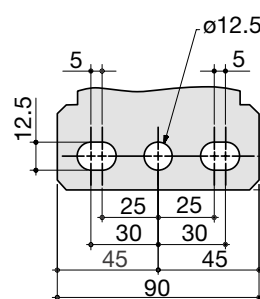

svr\_088\_a\_1\_x\_cat

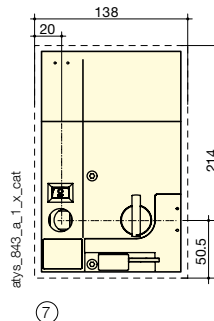

1. Padlocking Facility: Locking bracket for up to 3 padlocks of dia. 4 – 8mm
2. Emergency manual operation: Maximum operating radius with an operating angle of 2x 90°
3. Connection and disconnection area
4. Mounting stand off with spacer accessory
5. Phase Barriers
6. Emergency removable handle
7. Flush mounting cutout dimensions for front door



To consider the space required for manual operation and wiring.  
(When using the ATyS d emergency handle: note 2).

Rating (A)	Overall dimensions		Terminal screens		Body				Switch mounting		Connection					
	B	AC	F 3p.	F 4p.	J 3p.	J 4p.	M 3p.	M 4p.	T	U	V	X	Y	Z1	AA	
800	370	461	504	584	307	387	255	335	80	50	60.5	47.5	7	66.5	321	
1000	370	461	504	584	307	387	255	335	80	50	60.5	47.5	7	66.5	321	
1250	370	461	504	584	307	387	255	335	80	60	65	47.5	7	66.5	330	
1600	380	531	596	716	399	519	347	467	120	90	44	53	8	67.5	288	

All dimensions in mm

### 6.1.3. Dimensions: Frame B8 (2000A to 3200A)

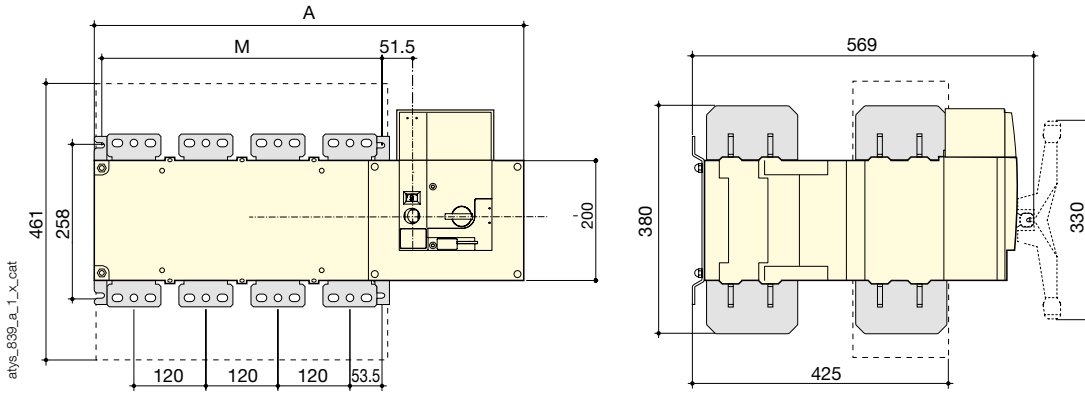

#### 2000 to 3200 A

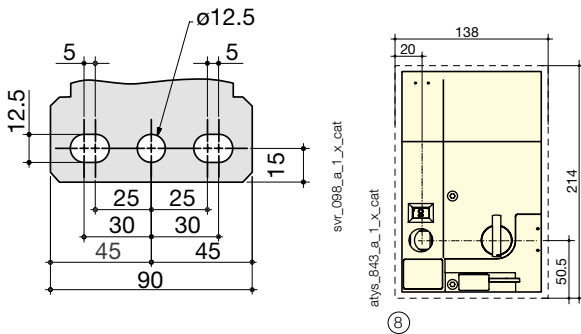

1. Padlocking Facility: Locking bracket for up to 3 padlocks of dia. 4 – 8mm
2. Emergency manual operation: Maximum operating radius with an operating angle of 2x 90°
3. Connection and disconnection area
4. Mounting stand off with spacer accessory
5. Phase Barriers
6. Emergency removable handle
7. Frame B8, (Dual frame) factory fitted power terminal connections
8. Flush mounting cutout dimensions for front door



To consider the space required for manual operation and wiring.  
(When using the ATyS p emergency handle: note 2).

Rating (A)	Overall dimensions		Switch mounting	
	A 3p.	A 4p.	M 3p.	M 4p.
2000 ... 3200	596	716	347	467

All dimensions in mm

## 6.2. Mounting orientation

125A to 630A	Recommended	OK	Not Allowed	Not Allowed
800A to 3200A	Recommended	Not Allowed	OK	Not Allowed



Always install the product on a flat and rigid surface.

ENGLISH

## 6.3. Assembly of customer mounted accessories



Never handle any customer mounted accessories while there may be the risk of voltage being or becoming present.

### 6.3.1. Bridging bar installation

125A to 630A

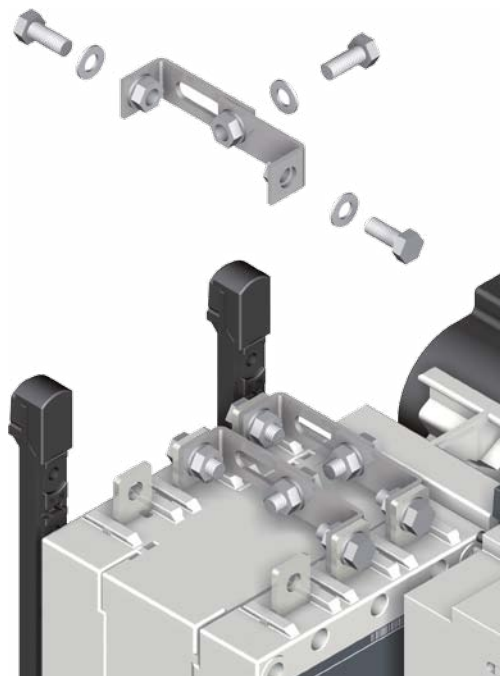

800A to 1600A

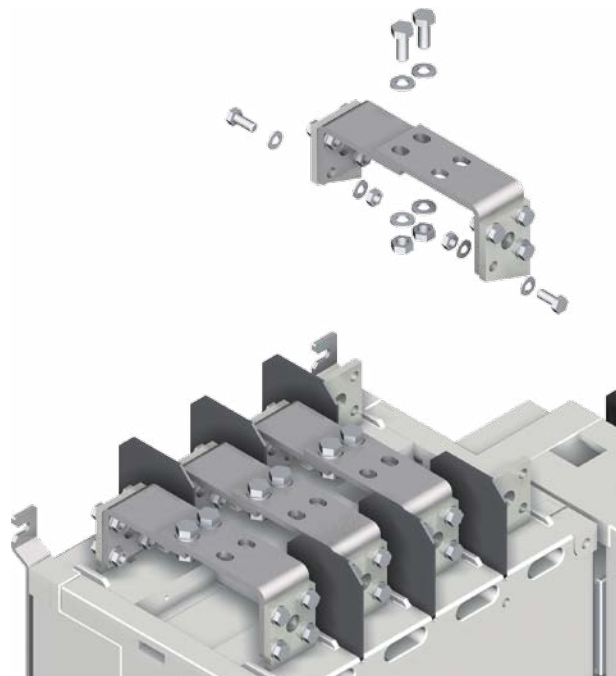

**It is possible to mount the bridging bars on either side of the switch**

Recommended tightening torque:

M6: 4,5 N.m  
 M8: 8,3 N.m  
 M10: 20 N.m  
 M12: 40 N.m

Maximum tightening torque:

M6: 5,4 N.m  
 M8: 13 N.m  
 M10: 26 N.m  
 M12: 45 N.m

## 6.3.2. Copper bar connection kits (2000A to 3200A : Frame B8)

 Conditions of use of these products may lead to a derating.

 [SOCOME C "Application guide"](#)



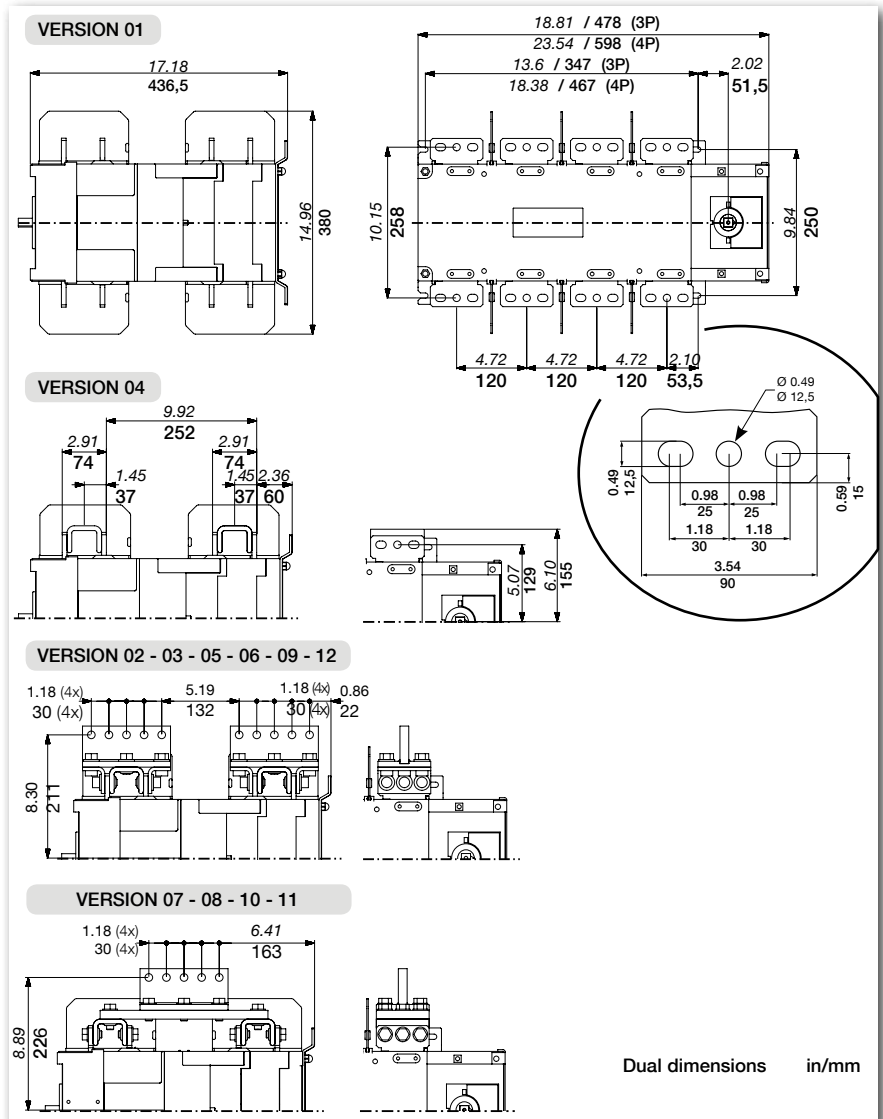
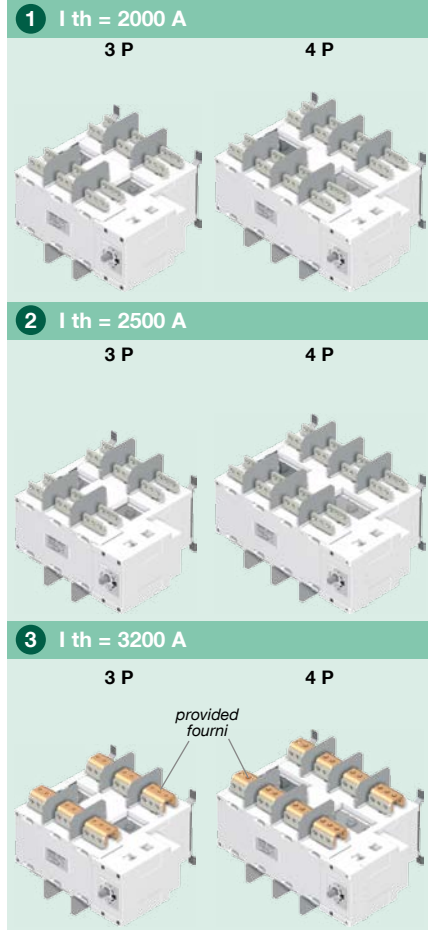







 [www.socomec.com](http://www.socomec.com)



Data for Bolts, Nuts and Washers for Busbar Connections.

 **TO BE SUPPLIED BY OTHERS**

**Connection reference numbers and contents:**

 x 1 <i>included with 3200A product as standard</i> <b>2619 1200</b>	 x 6 708 lb-in 80 Nm <b>2699 1200</b>	 x 1 +  x 6 708 lb-in 80 Nm <b>2629 1200</b>
 x 2 +  x 6 708 lb-in 80 Nm <b>2639 1200</b>	 x 1 +  x 6 708 lb-in 80 Nm <b>4109 0250</b>	 x 1 +  x 6 708 lb-in 80 Nm <b>4119 0320</b>

VERSION	H M12-35 6.8 - 6 x	Rondelle contact MOY. M M12 NFE 25 511	H M12
01	12 x	6 x	6 x
02	6 x	3 x	3 x
03	10 x	5 x	5 x
04	A H M12-35 6.8 - 3 x	3 x	-
	B H M12-45 6.8 - 3 x	3 x	-
05	6 x	3 x	3 x
06	10 x	5 x	5 x
07	6 x	3 x	3 x
08	10 x	5 x	5 x
09	20 x	10 x	10 x
10	6 x	3 x	3 x
11	10 x	5 x	5 x
12	20 x	10 x	10 x

**Note:** Reference numbers and quantity given above and below are for one connection and per pole. For a full set multiply the quantity indicated by the number of poles (3 or 4 pole) and then multiply by 2 (N° of switches)



### 6.3.3. Incoming copper bar connection kit assembly

2000A – 2500A (Minimum Cu bar section 2x100x10mm)

VERSION 01

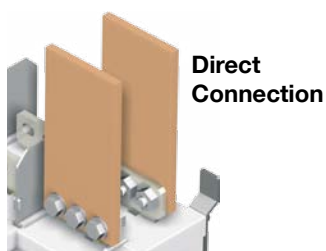

VERSION 02

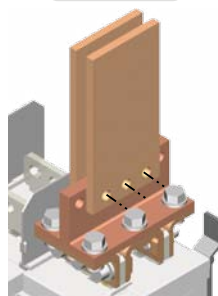

VERSION 03

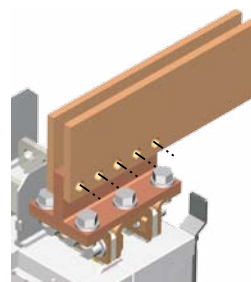

**V2 & V3**

Kit :  
2619 1200 x 1  
2629 1200 x 1  
2639 1200 x 1

3200A (Minimum Cu bar section 3x100x10mm)

VERSION 04

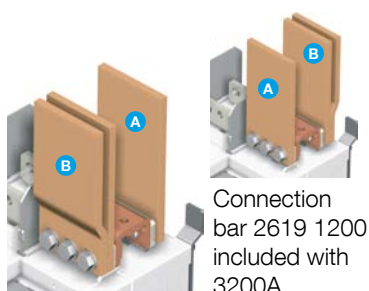

VERSION 05

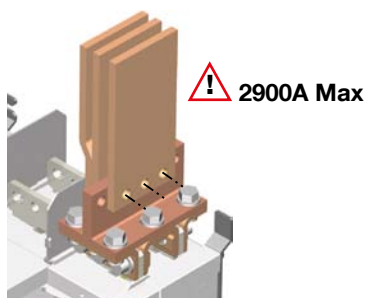

VERSION 06

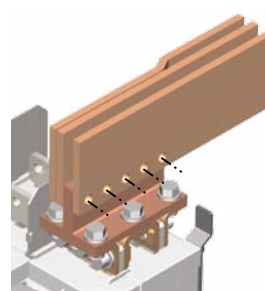

**V5 & V6**

Kit :  
2629 1200 x 1  
2639 1200 x 1

### 6.3.4. Outgoing bridge connection assembly

2000A – 2500A (Minimum Cu bar section 2x100x10mm)

VERSION 07

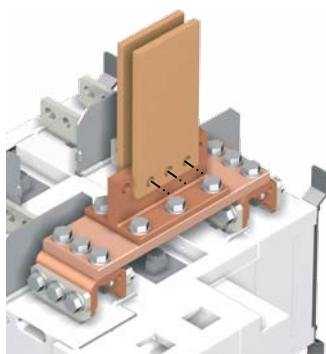

VERSION 08

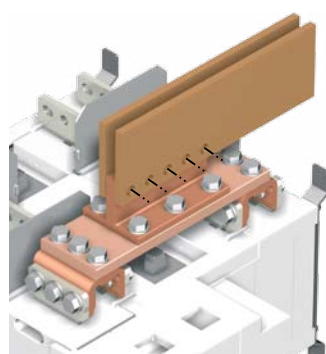

VERSION 09

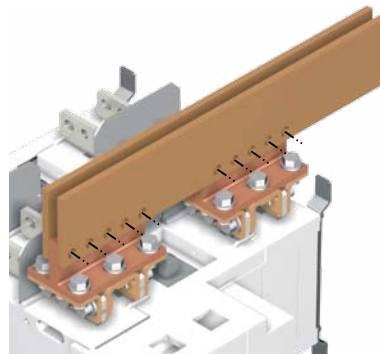

**V7 & V8**

Kit :  
2619 1200 x 2  
2699 1200 x 2  
2629 1200 x 1  
4109 1250 x 1

**V9**

Kit :  
2619 1200 x 2  
2629 1200 x 2  
2639 1200 x 2

3200A (Minimum Cu bar section 3x100x10mm)

VERSION 10

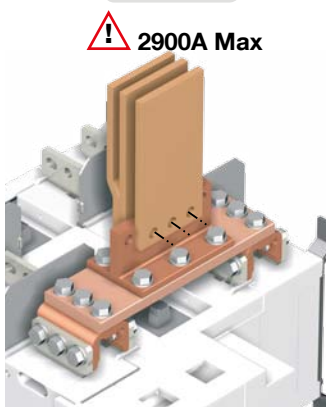

VERSION 11

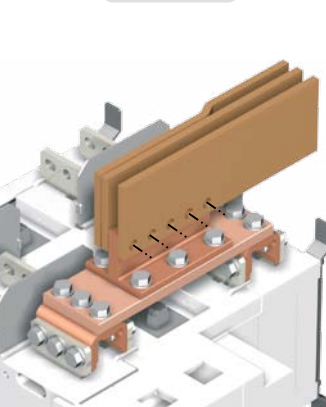

VERSION 12

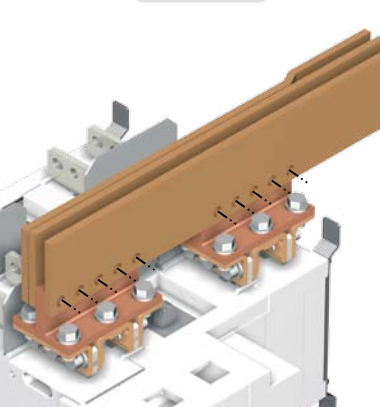

**V10 & V11**

Kit :  
2619 1200 x 2  
2699 1200 x 2  
2629 1200 x 1  
4109 0320 x 1

**V12**

Kit :  
2619 1200 x 2  
2629 1200 x 2  
2639 1200 x 2

### 6.3.5. Terminal shrouds

Available from 125A to 630A  
Frame B3 to Frame B5:

- Upstream, downstream, front or rear mounting.
- When fitted with bridging bars only the front terminal shrouds are to be installed.

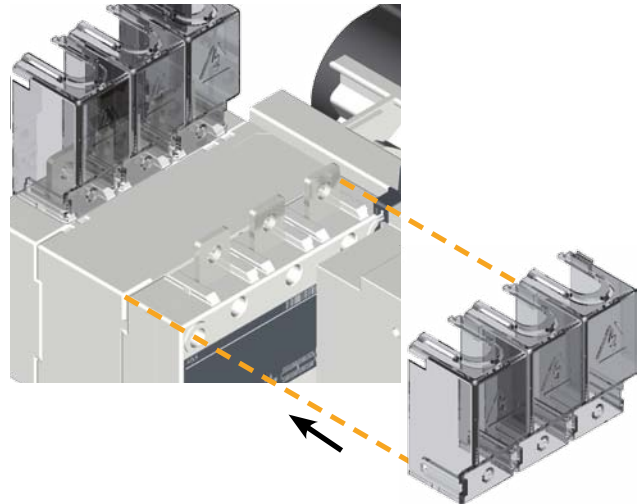

### 6.3.6. Terminal screens

125A to 630A

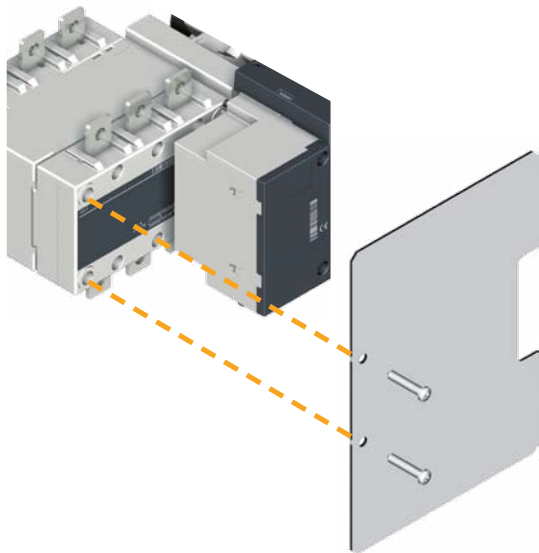

630A to 1600A

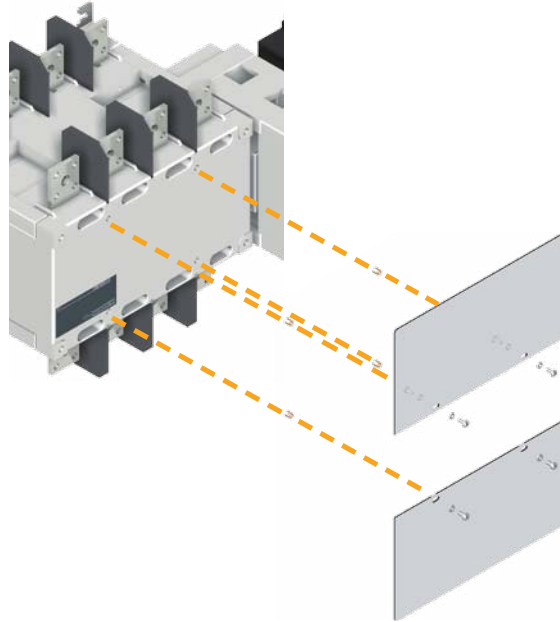

2000A to 3200A

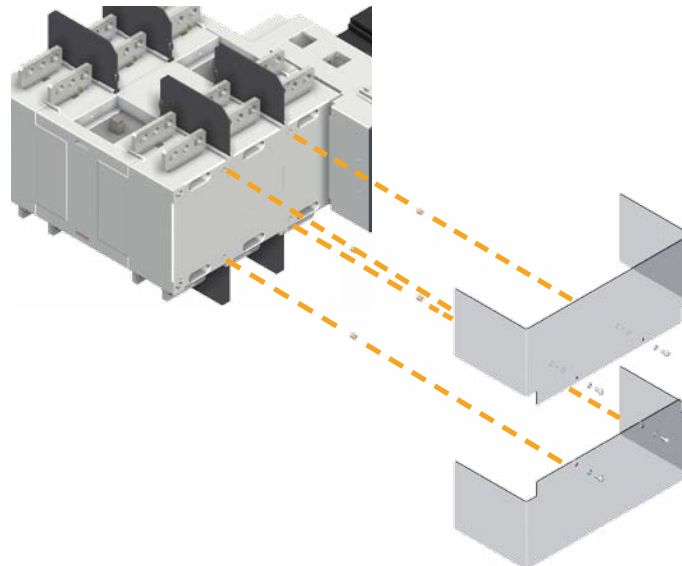

### 6.3.7. External Power supply (400VAC - 230VAC)

Power Transformer intended for 400VAC, Phase to Phase voltage applications that do not provide the availability of a neutral conductor. Transformer data: 400VAC – 230VAC: 200VA.

In this case the ATyS d will require 2 transformers to be connected as shown below.

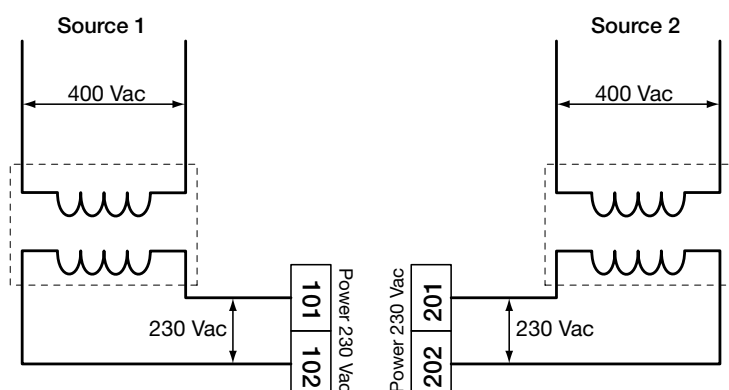

### 6.3.8. Raised mounting spacers

Available for 125A to 630A ratings only  
Frames B3, B4 and B5

1 set including 2 spacers raises the device's terminals 10mm away from the bottom of the enclosure or frame on which the device is mounted. These may also be used to replace the original mounting spacers.



## 6.4. Factory fitted accessories

### 6.4.1. Padlocking key interlocks

Intended for locking the electrical control and the backup control in position 0 using a RONIS EL11AP lock (factory fitted). As standard, key locking is in the 0 position.

Optionally and when including the option “padlocking in 3 positions” key locking will be in positions I, 0 or II

#### 125A to 630A

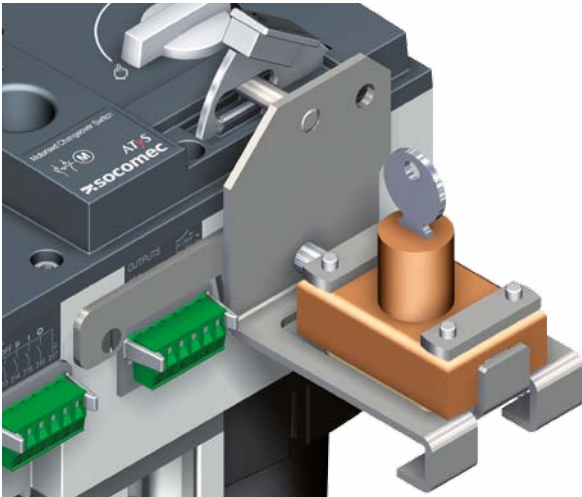

#### 800A to 3200A

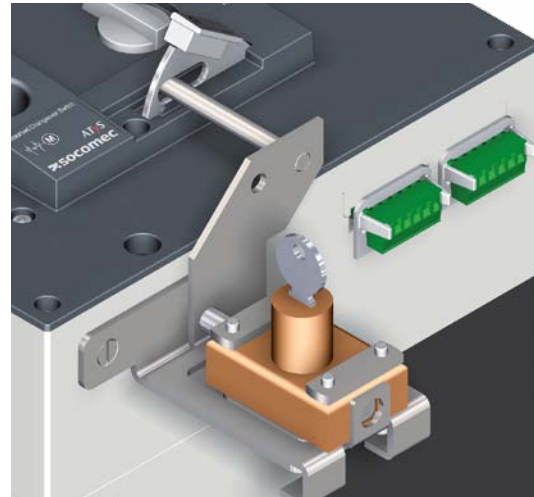

### 6.4.2. Additional auxiliary contacts

Intended for pre breaking and signaling of positions I and II:

One additional NO / NC auxiliary contact for each position (factory fitted).

#### 125A to 630A (Optional)

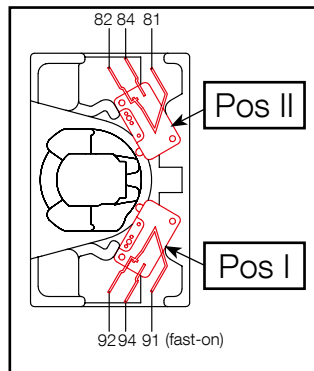
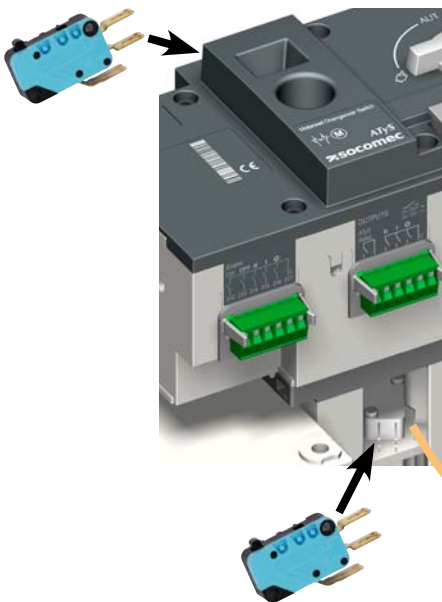

#### 800A to 1600A (Optional) 2000A to 3200A (Standard)

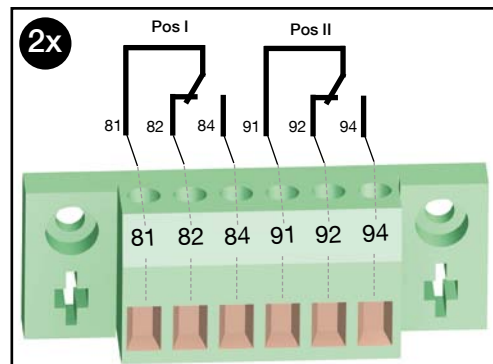

## 7. CONNECTIONS

### 7.1. Power circuits

#### 7.1.1. Cable or bar connections

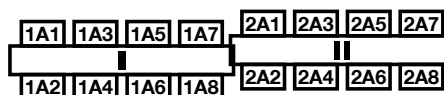
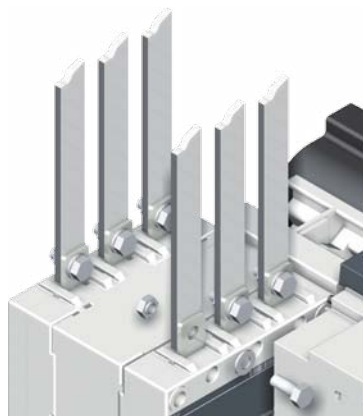

Recommended tightening torque: <ul style="list-style-type: none"> <li>• M6: 4,5 N.m</li> <li>• M8: 8,3 N.m</li> <li>• M10: 20 N.m</li> <li>• M12: 40 N.m</li> </ul>	Maximum tightening torque: <ul style="list-style-type: none"> <li>• M6: 5,4 N.m</li> <li>• M8: 13 N.m</li> <li>• M10: 26 N.m</li> <li>• M12: 45 N.m</li> </ul>
---	--

#### 7.1.2. Power connection terminals

##### 125A to 630A

Refer to section "Product dimensions", page 20 for power connection terminals up to 630A.

##### 800A to 1000A

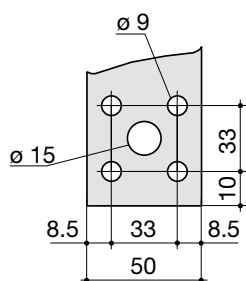

svr\_077\_a\_1\_x\_cat

##### 1250A

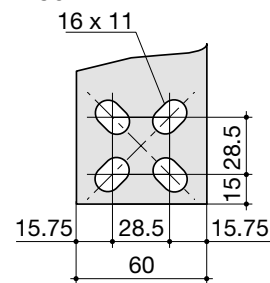

svr\_078\_b\_1\_x\_cat

##### 1600A to 3200A

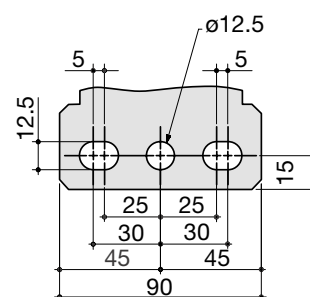

#### 7.1.3. Power connection cross-section

	B3		B4				B5		B6			B7		B8	
	125A	160A	200A	250A	315A	400A	500A	630A	800A	1000A	1250A	1600A	2000A	2500A	3200A
Minimum cables section Cu (mm <sup>2</sup> ), lth	50	70	95	120	185	240	2x150	2x185	2x240	-	-	-	-	-	-
Minimum bars section Cu (mm <sup>2</sup> ), lth	-	-	-	-	-	-	2x30 x5	2x40 x5	2x50 x5	2x60 x5	2x80 x5	2x100 x5	3x100 x5	4x100 x5	3x100 x10
Maximum cables section Cu (mm <sup>2</sup> )	50	95	150	150	240	240	2x300	2x300	2x300	4x185	4x185	6x185	-	-	-
Maximum bars width Cu (mm)	20	20	32	32	32	32	50	50	63	63	63	100	100	100	100

Note for all ratings: Take into account the connection cable lengths and/or others environmental specific operating conditions.

## 7.2. Control circuits

### 7.2.1. Typical ATyS d wiring

Example: Control wiring for a 400VAC application having a 3 phase and neutral supply.

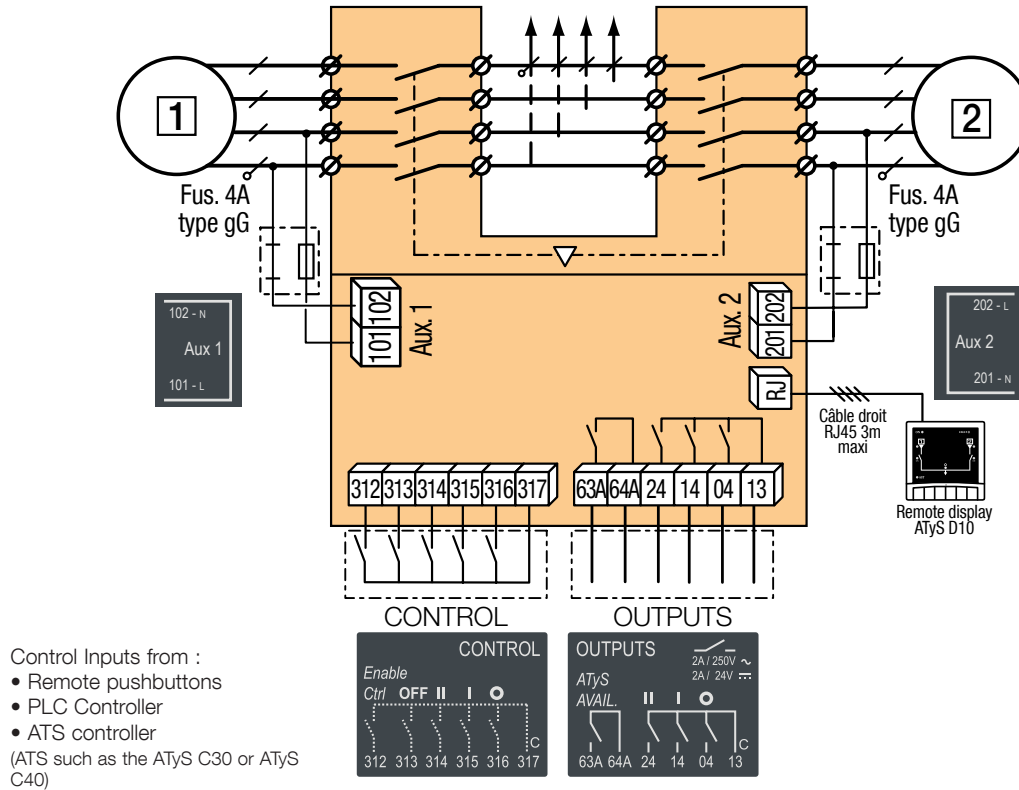

Verify that the Auxiliary power supply feeding terminals 301 and 302 are within the limits of 208VAC -> 277VAC  $\pm$ 20%.



Do not handle any control or power cables connected to the ATyS when voltage may be present.

## 7.2.2. ATyS d input and output contacts

### 7.2.2.1. Terminal denomination, description and characteristics.

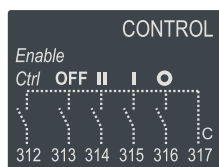
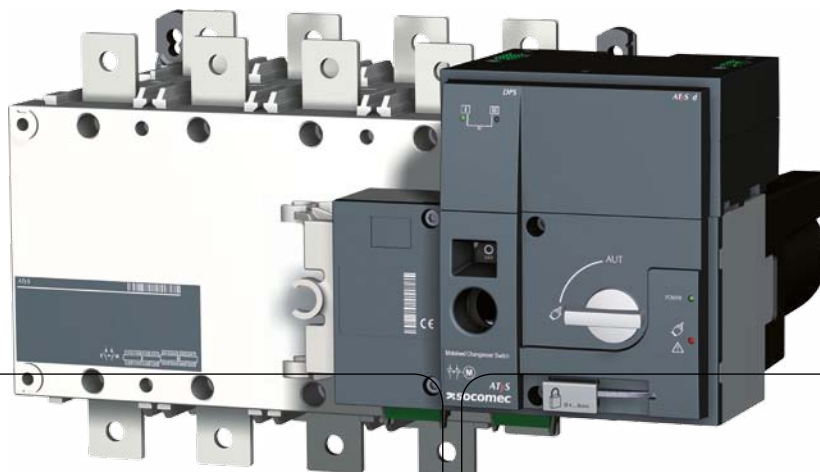

Control Enable:	312	Prod Avail Common	63A
Override to OFF:	313	Prod Avail O/P:	64A
Sw to Pos II I/P:	314	Pos II Aux Contact:	24
Sw to Pos I I/P:	315	Pos I Aux Contact:	14
Sw to Pos 0 I/P:	316	Pos 0 Aux Contact:	04
Common:	317	Common:	13

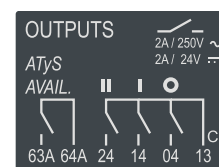

#### Aux Supply 1

Power - 230V  
208-277 Vac ±20%  
(166 - 332Vac)



Aux. supply 230V~  
(208-277V~ ±1-20%)

#### Aux Supply 2

Power - 230V  
208-277 Vac ±20%  
(166 - 332Vac)



RJ45 to  
ATyS D10



Denomination	Terminal	Description	Characteristics	Recommended Cable Section
<b>Aux Power supply Input</b>	101	Power supply 1 – L	208 - 277VAC ± 20% : 50/60Hz	1,5mm
	102	Power supply 1 – N		
	201	Power supply 2 – L		
	202	Power supply 2 – L		
<b>Control Inputs</b>	312	Remote Control Mode Enable when closed with 317	<b>Attn:</b> Do not connect to any Power supply  Max cable length 100m	1,5mm
	313	Position 0 order if closed with 317. (Priority order input forcing the product to remote control mode and 0 position)		
	314	Position II order if closed with 317		
	315	Position I order if closed with 317		
	316	Position 0 order if closed with 317		
	317	Common control terminal for 312 - 316 ATyS d (Specific Voltage Supply)		
<b>Signalisation Outputs</b>	13	Common I - 0 - II for Aux Contacts	Dry Contacts 5A AC1 / 250V	1,5mm
	04	Aux Contact Position 0 - Normally Open Contact		
	14	Aux Contact position I : Normally Open Contact		
	24	Aux Contact position II : Normally Open Contact		
	63A	Product Available : Normally Open Contact. Closed when the ATyS d is in Auto mode and motorisation is operational. (No Fault powered and ready to changeover)		
	64A			
<b>Additional Aux Contact</b>	81	Common for Aux Contacts positions I	Dry Contacts 5A AC1 / 250V	1,5 – 2,5mm
	82	Aux Contact position I: Normally Closed Contact		
	84	Aux Contact position I: Normally Open Contact		
	91	Common for Aux Contacts positions II		
	92	Aux Contact position II: Normally Closed Contact		
	94	Aux Contact position II: Normally Open Contact		



Do not connect terminals 312 to 317 to any power supply. These order inputs are powered through terminal 317 and external dry contacts ONLY.

### 7.2.3. ATyS d RTSE + ATS Controllers type ATyS C30 and ATyS C40

Refer to the relevant ATS controller instruction manual for ATyS C30 and ATyS C40 details

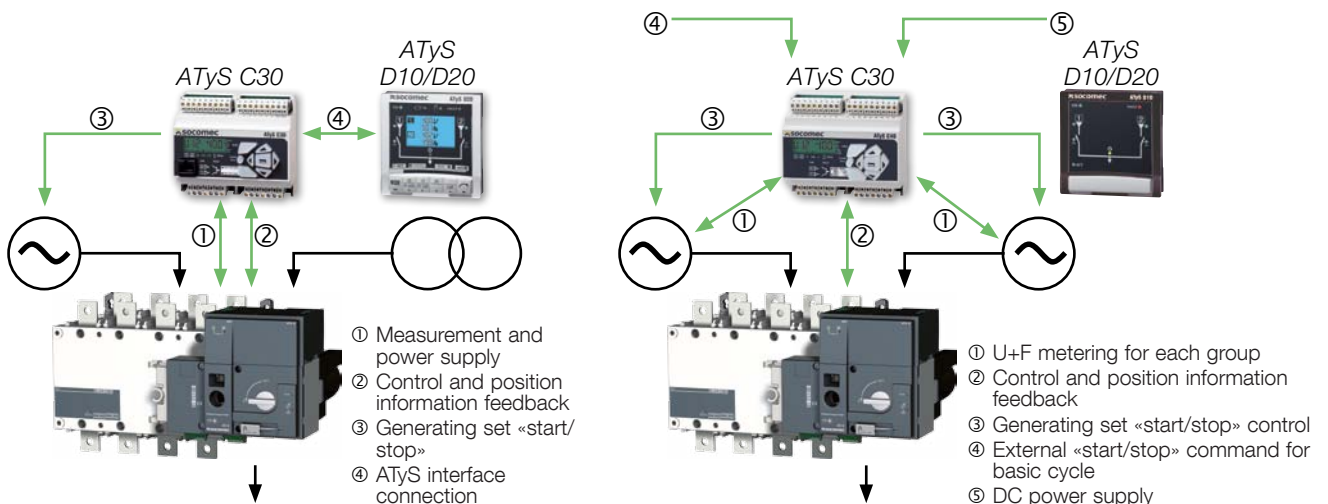















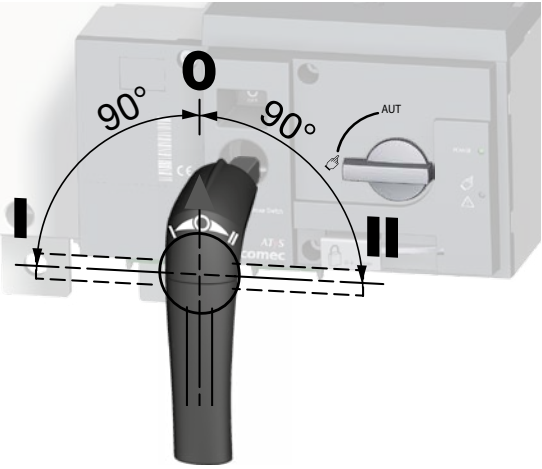

## 8. ATyS d OPERATING MODES

The ATyS d includes 3 safe and distinct operating modes through a selector switch located on the front of the product. As standard the ATyS d is delivered with a selector switch however a key lock type selector switch is available on option. (To be specified at order by the addition of “-K” at the end of the standard reference).

The modes of operation are as follows:

- Auto Mode: “Remotely operated transfer switching”
- Manual Mode: “Local emergency manual operation”
- Locked Mode: “Secure locked padlocking facility”

<p><b>AUT</b> MODE</p>		<p><b>AUT</b></p>  	<p><b>AUTO MODE:</b></p> <ul style="list-style-type: none"> <li>• Activates the remote control inputs and the ATS controller automation.</li> <li>• Inhibits the padlocking facility</li> <li>• Inhibits the insertion of the manual operation handle when in AUT Mode</li> </ul> <p>AUTO Mode position is inhibited when padlocked or when the handle for manual operation is inserted into the ATyS d.</p>
<p>MODE</p> 		<p><b>AUT</b></p>  	<p><b>MANUAL MODE: (Not Padlocked)</b></p> <ul style="list-style-type: none"> <li>• Inhibits the control inputs.</li> <li>• Allows to insert the handle for emergency manual operation.</li> <li>• Allows padlocking in 0 Position. <i>(With the handle for manual operation removed)</i></li> </ul> <p>Turning the selector switch to  from AUT and back to AUT resets a fault state.</p>
<p>MODE</p>  		<p><b>AUT</b></p>  	<p><b>MANUAL MODE: (Padlocked)</b></p> <ul style="list-style-type: none"> <li>• Inhibits the control inputs.</li> <li>• Inhibits insertion of the emergency handle.</li> <li>• Allows padlocking when in 0 Position.</li> </ul>   POS 0 <p>Padlocking in position I - 0 and II is possible when the optional function is included in the ATyS d. (Refer to product catalogue)</p>



Depending on the state of the ATyS d the ATS automation may change the switch position as soon as the mode selector is switched to AUT. This is a normal operation.

## 8.1. Manual operation

### 8.1.1. Emergency manual operation

The ATyS d can be manually operated as a “Manual Transfer Switch Equipment – MTSE” whilst retaining the electrical characteristics and performance of the power switching function. This function is usually used in case of emergencies or during maintenance.

To operate the ATyS d manually ensure that no live parts are accessible, turn the front selector switch into the manual position (see page 14) and insert the handle (see page 14) into the emergency handle shaft location hole provided (see 5.2. Product identification, page 15).

Turn the handle 90° clockwise or anti-clockwise (depending on the position to be reached) for each consecutive change in position. I -> O -> II -> O -> I.



Ensure to verify the product position and direction of rotation before effecting manual operation.

Ensure to remove the handle from the product before changing the selector switch back to AUT position.

### 8.1.2. Padlocking

The ATyS d can be padlocked in the 0 position as standard whilst padlocking in positions I, O or II is available as a factory fitted option.

To padlock the ATyS d first ensure that the ATyS d mode selector switch is on Manual then ensure that the emergency manual operation handle is not inserted into the location hole. (Remove if inserted).

Pull the padlocking mechanism outwards to reveal the slot for inserting up to 3x dia. 4 - 8mm padlocks.

Padlock the device with approved quality padlocks of minimum diameter 4mm and maximum diameter of 8mm. A maximum of 3x 8mm padlocks may be padlocked onto the ATyS d to padlocking mechanism.



As standard, padlocking is only made possible in the “O position”, when in manual mode and with the emergency handle not inserted.

## 8.2. Electrical operation

### 8.2.1. Power supply

The ATyS d includes a dual power supply and is to be powered between terminals 101 - 102 and 201 - 202 (2 different supplies - main & alternative) within the limit of:

- 2x 208 – 277Vac  $\pm 20\%$  (166 – 332Vac)
- 50/60Hz  $\pm 10\%$

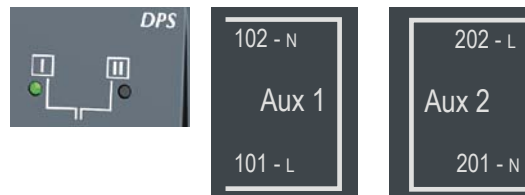

Current Input:

- 10mA (Standby mode)
- 15A max (Switching mode)

Surge Protection :

- $V_{in\_sg}$ : 4 / 8KV – 1.2/50 $\mu$ s according to IEC 61010-1

Terminal connector:

- Minimum 1.5mm<sup>2</sup>
- Maximum 2.5mm<sup>2</sup>

### 8.2.2. Fixed inputs

#### 8.2.2.1. Description

The ATyS d includes for 5 off fixed inputs through a 6 pin connector installed on the motorisation module. No additional power supply should be used on these contacts as the inputs **MUST** be used with the common supply taken from terminal 317.

At least one of the ATyS d aux power supplies (101 – 102 or 201 - 202) must be available to activate inputs 312 to 317.

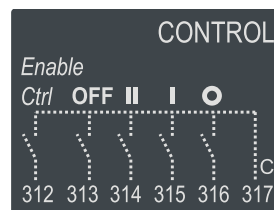

Pulse duration for activation of contact inputs:  $\geq 60$ ms.

- **Pin 312:** Remote Control Mode Enable when closed with 317. This contact must be closed with 317 so as to activate all analogue inputs except for 313 that takes priority and is active immaterial of the state of input 312.
- **Pin 313:** Position 0 order if closed with 317 when in AUTO. **(Force ATyS d to the OFF Position).** This is a “Priority Order Input” meaning that when closed with 317 it takes priority over all other electrical commands. The ATyS d will remain in 0 position as long as the contact 313 – 317 remains closed. Once the contact is open the ATyS d is ready to receive new orders. This contact order is independent of other inputs and is also enabled without 312 connected to 317. Impulse duration to activate and switch to position O is a minimum of 60ms.
- **Pin 314:** Position II order if closed with 317. This contact is active with the ATyS d in AUT mode with contact 312 – 317 closed and 313 – 317 open. Impulse duration to activate and switch to position II is a minimum of 60ms.
- **Pin 315:**- Position I order if closed with 317. This contact is active with the ATyS d in AUT mode with contact 312 – 317 closed and 313 – 317 open. Impulse duration to activate and switch to position I is a minimum of 60ms.
- **Pin 316:**- Position 0 order if closed with 317. This contact is active with the ATyS d in AUT mode with contact 312 – 317 closed and 313 – 317 open. Impulse duration to activate and switch to position O is a minimum of 60ms. For contactor logic maintain contacts on between terminal 316 and 317.
- **Pin 317:**- Common for inputs 312 to 316.

### 8.2.2.2. Technical data

Motorisation Module	
Input Qty:	5
Direct Voltage Vin :	300 VAC (On any input with respect to ground)
Direct Current Iin:	0.35 to 0.5mA
Line resistance:	1kΩ
Line length :	100m (Min. wire 1.5mm <sup>2</sup> #16AWG)
Pulse duration:	60ms
Power per Input:	0.06VA
Surge protection Vin_sg:	4.8kV (1.2/50μs surge)
ESD withstand voltage (Contact/air)	2/4kV
Insulation (Common mode)	4.8kVAC (Between I/P and all common parts)
Terminal connector:	1.5mm <sup>2</sup> minimum / 2.5mm <sup>2</sup> max

### 8.2.2.3. Remote control logic

Remote switching operation can be driven in AUT mode by external volt free contacts as described above using input contacts 312 to 317.

Depending on the wiring configuration there are two types of logic that may be applied to the ATyS d.

- Impulse logic or
- Contactor logic.

In remote control, the ATyS d inputs give priority to orders I and II over O therefore contactor logic can be implemented by simply bridging terminals 316 and 317.

(NOTE: 312 – 317 closed / Force ATyS d to OFF Position, takes priority over all other orders no matter of the control logic used.)

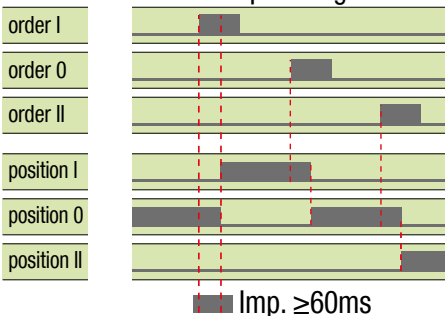
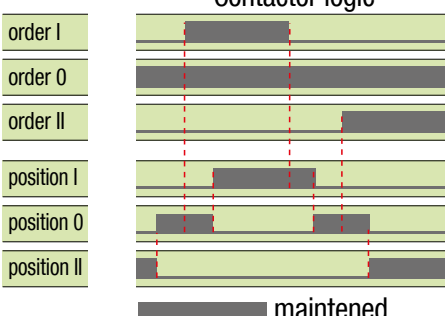
<p><b>Impulse logic:</b></p> <p>The ATyS d is driven to a stable position (I – O – II) after receiving an impulse order.</p> <ul style="list-style-type: none"> <li>• A switching command of at least 60 ms is necessary to initiate the switching operation.</li> <li>• Orders I and II have priority over order O.</li> </ul> <p>Note: The logic diagrams exclude the transfer times.</p>	<p style="text-align: center;"><b>Impulse logic</b></p>  <p style="text-align: center;">(Note : Excludes position switching delays)</p>
<p><b>Contactor Logic :</b></p> <p>The ATyS is driven to a specific position (I or II) for as long as the order is maintained.</p> <ul style="list-style-type: none"> <li>• Order O is maintained. (Bridge 316 – 317)</li> <li>• Orders I and II have priority over order O.</li> <li>• Orders I and II have equal priority. (1st order received is held until no longer maintained).</li> <li>• If order I or II disappears, the device returns to zero position. (With the power supply available).</li> </ul>	<p style="text-align: center;"><b>Contactor logic</b></p>  <p style="text-align: center;">(Note : Excludes position switching delays)</p>

## 8.2.3. Fixed outputs - Dry contacts

### 8.2.3.1. Description

As standard, the ATyS d is equipped with four fixed outputs located on the motorisation module.

(Dry contacts to be powered by the user).

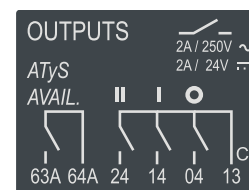

### 8.2.3.2. Position auxiliary contact

The ATyS d is equipped with integrated position (I – O – II) auxiliary contact outputs through 3 off micro switches.

#### Pins 13, 04, 14, 24

(Normally Open contacts with pin 13 as common)

### 8.2.3.3. ATyS d Product available output (motorisation)

#### Pin 63A – 64A

(Normally Open contact that is held closed when the motorisation is available).

This contact gives constant feedback about the product's availability and it's capacity to transfer from the main supply to the alternative. The feedback given is relative to the motorisation module excluding the ATS controller that may be monitored separately.

The ATyS d performs a self diagnostics test on the motorisation module at startup, when put from Manual -> Auto and then every 5 minutes. This test ensures that the ATyS d is operational in terms of control inputs. Should one of the tests fail, a second test is performed to reconfirm the error state. Should the ATyS d motorisation module become unavailable, contact 63A – 64A are opened, the power/ready LED's are switched off, and the fault LED is activated. The fault LED will remain active for as long as sufficient power is available and the fault condition is not reset. The fault is reset when the product is switched from AUT -> Manual -> Auto mode.

ATyS d (Motorisation) Product Available / Unavailable Watchdog relay will open for any of the following reasons below: For added security, "Product Availability" is informative and does not necessarily inhibit motor operation.

Product Unavailable + Warning LED Condition:	Inhibition
Product in manual mode	Yes
Motor not detected (Autotest)	No
Control voltage out of range	Yes
Operating factor fault active (N° of operations / min)	Yes
Powerfail active	Yes
Customer input autotest failed	No
Invalid product customisation	No
Abnormal switching when not in manual mode	Yes
Requested position not reached	Yes
Locked mode active when not in manual mode	Yes
External Fault -> User input	No
Unexpected current flowing through the motor when idle	Yes

Sampling rate for the above is every 10 ms

Exception: motor detection sampling rate is every 5 min

#### 8.2.3.4. Technical data

Auxiliary Contact Quantity	4
Configuration	NO
Mechanical Endurance	100k cycles
Response Time	5 – 10 ms
Startup duration	200ms
Rated Voltage / Switching Voltage	250VAC
Rated Current	5A
Surge protection Vin_sg:	4.8kV (1.2/50µs surge)
ESD withstand voltage (Contact/air):	2/4kV
Dielectric Strength contact/parts:	4.8kVAC (Reinforced Insulation)
Insulation:	4.8KVAC
Output Terminal:	1.5mm <sup>2</sup> minimum / 2.5mm <sup>2</sup> maximum

# 9. CHARACTERISTICS

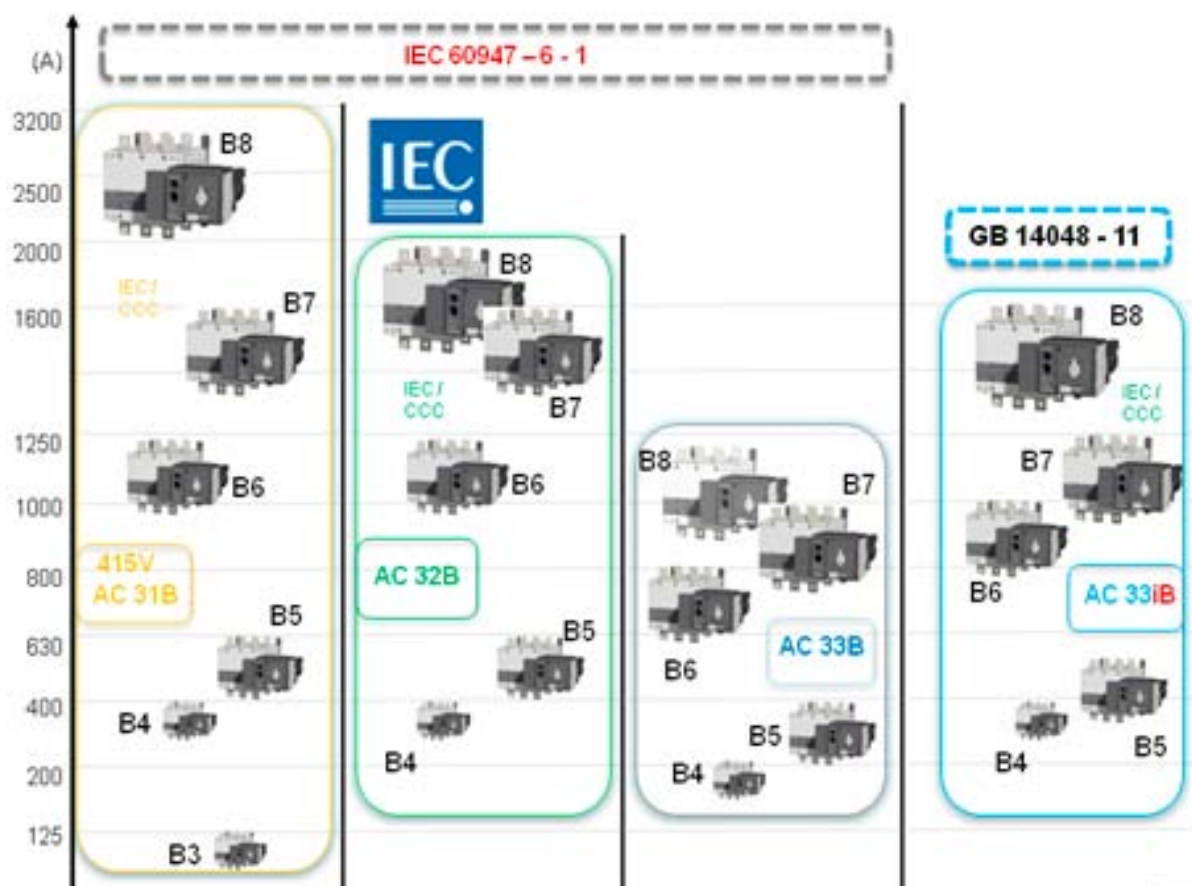

ENGLISH

# Characteristics according to IEC 60947-3 and IEC 60947-6-1

## 125 to 630 A

Frame	B3			B4			B5		
<b>Thermal current I<sub>th</sub> at 40°C</b>	<b>125 A</b>	<b>160 A</b>	<b>200 A</b>	<b>250 A</b>	<b>315 A</b>	<b>400 A</b>	<b>500 A</b>	<b>630 A</b>	
Rated insulation voltage U <sub>i</sub> (V)	800	800	800	1000	1000	1000	1000	1000	
Rated impulse withstand voltage U <sub>imp</sub> (kV)	8	8	8	12	12	12	12	12	
<b>Rated operational currents I<sub>e</sub> (A) according to IEC 60947-3</b>									
<b>Rated voltage</b>	<b>Utilisation category</b>	<b>A/B<sup>(1)</sup></b>	<b>A/B<sup>(1)</sup></b>	<b>A/B<sup>(1)</sup></b>	<b>A/B<sup>(1)</sup></b>	<b>A/B<sup>(1)</sup></b>	<b>A/B<sup>(1)</sup></b>	<b>A/B<sup>(1)</sup></b>	<b>A/B<sup>(1)</sup></b>
415 VAC	AC-20 A / AC-20 B	125/125	160/160	200/200	250/250	315/315	400/400	500/500	630/630
415 VAC	AC-21 A / AC-21 B	125/125	160/160	200/200	250/250	315/315	400/400	500/500	630/630
415 VAC	AC-22 A / AC-22 B	125/125	160/160	200/200	250/250	315/315	400/400	500/500	630/630
415 VAC	AC-23 A / AC-23 B	125/125	160/160	200/200	200/200	315/315	400/400	500/500	630/630
500 VAC	AC-20 A / AC-20 B	125/125	160/160	200/200	250/250	315/315	400/400	500/500	630/630
500 VAC	AC-21 A / AC-21 B	125/125	160/160	200/200	250/250	315/315	400/400	500/500	630/630
500 VAC	AC-22 A / AC-22 B	125/125	160/160	200/200	200/250	200/315	200/400	500/500	500/500
500 VAC	AC-23 A / AC-23 B	80/80	80/80	80/80	200/200	200/200	200/200	500/500	400/400
690 VAC	AC-20 A / AC-20 B	125/125	160/160	200/200	250/250	315/315	400/400	500/500	630/630
690 VAC	AC-21 A / AC-21 B	125/125	160/160	200/200	200/200	200/200	200/200	500/500	500/500
690 VAC	AC-22 A / AC-22 B	125/125	125/125	125/125	160/160	160/160	160/160	400/400	400/400
690 VAC	AC-23 A / AC-23 B	63/80	63/80	63/80	125/125	125/125	125/125	400/400	400/400
220 VDC	DC-20 A / DC-20 B	125/125	160/160	200/200	250/250	315/315	400/400	500/500	630/630
220 VDC	DC-21 A / DC-21 B	125/125	160/160	200/200	250/250	250/250	250/250	500/500	630/630
220 VDC	DC-22 A / DC-22 B	125/125	160/160	200/200	250/250	250/250	250/250	500/500	630/630
220 VDC	DC-23 A / DC-23 B	125/125	125/125	125/125	200/200	200/200	200/200	500/500	630/630
440 VDC	DC-20 A / DC-20 B	125/125	160/160	200/200	250/250	315/315	400/400	500/500	630/630
440 VDC	DC-21 A / DC-21 B	125/125 <sup>(2)</sup>	125/125 <sup>(2)</sup>	125/125 <sup>(2)</sup>	200/200 <sup>(2)</sup>	200/200 <sup>(2)</sup>	200/200 <sup>(2)</sup>	500/500 <sup>(2)</sup>	630/630 <sup>(2)</sup>
440 VDC	DC-22 A / DC-22 B	125/125 <sup>(2)</sup>	125/125 <sup>(2)</sup>	125/125 <sup>(2)</sup>	200/200 <sup>(2)</sup>	200/200 <sup>(2)</sup>	200/200 <sup>(2)</sup>	500/500 <sup>(2)</sup>	630/630 <sup>(2)</sup>
440 VDC	DC-23 A / DC-23 B	125/125 <sup>(3)</sup>	125/125 <sup>(3)</sup>	125/125 <sup>(3)</sup>	200/200 <sup>(3)</sup>	200/200 <sup>(3)</sup>	200/200 <sup>(3)</sup>	500/500 <sup>(3)</sup>	630/630 <sup>(3)</sup>
<b>Rated operational currents I<sub>e</sub> (A) according to IEC 60947-6-1</b>									
<b>Rated voltage</b>	<b>Utilisation category</b>								
415 VAC	AC-31 B	125	160	200	250	315	400	500	630
415 VAC	AC-32 B				200	315	400	500	500
415 VAC	AC-33 B				200	200	200	400	400
<b>Fuse protected short-circuit withstand as per IEC 60947-3 at 690 VAC</b>									
Prospective short-circuit current (kA rms)		100 <sup>(4)</sup>	100 <sup>(4)</sup>	50 <sup>(4)</sup>	50	50	50	50	50
Associated fuse rating (A)		125	160	200	250	315	400	500	630
<b>Circuit breaker protected short-circuit withstand with any circuit breaker that ensures tripping in less than 0.3s<sup>(5)</sup></b>									
Rated short-time withstand current 0.3s low (kA rms)		12 <sup>(4)</sup>	12 <sup>(4)</sup>	12 <sup>(4)</sup>	15	15	15	17	17
<b>Short-circuit withstand without protection as per IEC 60947-3 at 690 VAC</b>									
Rated short-time withstand current 1s low (kA rms)		7 <sup>(4)</sup>	7 <sup>(4)</sup>	7 <sup>(4)</sup>	8	8	8	10	10
Rated short-circuit making capacity I <sub>cm</sub> (kA peak)		11.9	11.9	11.9	22	22	22	17	17
<b>Short-circuit withstand without protection as per IEC 60947-6-1 at 415 VAC</b>									
Rated short-time withstand current 30/60ms low (kA rms)					10 / -	10 / -	10 / -	- / 10	- / 12.6
<b>Connection</b>									
Maximum Cu cable cross-section (mm <sup>2</sup> )		35	50	70	95	150	185	240	2 x 150
Minimum Cu busbar cross-section (mm <sup>2</sup> )									2 x 30 x 5
Maximum Cu cable cross-section (mm <sup>2</sup> )		50	95	120	150	240	240	2 x 185	2 x 300
Maximum Cu busbar width (mm)		25	25	25	32	32	32	50	50
Tightening torque mini / maxi (Nm)		9/13	9/13	9/13	20/26	20/26	20/26	20/26	20/26
<b>Switching time (Standard setting)</b>									
I-II or II-I (s)		0.75	0.75	0.75	1.3	1.3	1.3	1.3	1.3
I-0 or 0-II (s)		0.45	0.45	0.45	0.85	0.85	0.85	0.85	0.85
Duration of "electrical blackout" I-II (s) minimum		0.3	0.3	0.3	0.6	0.6	0.6	0.6	0.6
<b>Power supply</b>									
min / max (VAC)		166/332	166/332	166/332	166/332	166/332	166/332	166/332	166/332
<b>Control supply power demand</b>									
Power supply 230 VAC inrush / nominal (VA) - ATyS		184/92	184/92	184/92	276/115	276/115	276/115	276/150	276/150
Power supply 230 VAC inrush / nominal (VA) - ATyS d, t, g, p		206/114	206/114	206/114	298/137	298/137	298/137	298/172	298/172
<b>Mechanical characteristics</b>									
Durability (number of operating cycles)		10 000	10 000	10 000	8 000	8 000	8 000	5 000	5 000
Weight ATyS 3 P (kg)		5.7	5.7	5.7	6.6	6.7	6.7	11.4	11.9
Weight ATyS 4 P (kg)		6.9	6.9	6.9	7.4	7.8	7.8	13.3	14.0
Weight ATyS d 3 P (kg)		6.3	6.3	6.3	7.2	7.3	7.3	12.0	12.5
Weight ATyS d 4 P (kg)		7.5	7.5	7.5	8.0	8.4	8.4	13.9	14.6
Weight ATyS t, g, p 3 P (kg)		6.8	6.8	6.8	7.7	7.8	7.8	12.5	13.0
Weight ATyS t, g, p 4 P (kg)		8.0	8.0	8.0	8.5	8.9	8.9	14.4	15.1

(1) Category with index A = frequent operation - Category with index B = infrequent operation.

(2) 3-pole device with 2 poles in series for the "+" and 1 pole for the "-".

(3) 4-pole device with 2 poles in series by polarity.

(4) At 415 VAC

(5) Value for coordination with any circuit breaker that ensures tripping in less than 0.3s.

For coordination with specific circuit-breaker references, higher short-circuit current values are available. Please consult us.



800 to 3200 A

Frame	B6			B7	B8		
Thermal current $I_{th}$ at 40°C	800 A	1000 A	1250 A	1600 A	2000 A	2500 A	3200 A
Rated insulation voltage $U_i$ (V)	1000	1000	1000	1000	1000	1000	1000
Rated impulse withstand voltage $U_{imp}$ (kV)	12	12	12	12	12	12	12

Courants assignés d'emploi le (A) selon CEI 60947-3

Rated voltage	Utilisation category	A/B <sup>(1)</sup>	A/B <sup>(1)</sup>	A/B <sup>(1)</sup>	A/B <sup>(1)</sup>	A/B <sup>(1)</sup>	A/B <sup>(1)</sup>	A/B <sup>(1)</sup>
415 VAC	AC-20 A / AC-20 B	800/800	1000/1000	1250/1250	1600/1600	2000/2000	2500/2500	3200/3200
415 VAC	AC-21 A / AC-21 B	800/800	1000/1000	1250/1250	1600/1600	-/2000	-/2500	-/3200
415 VAC	AC-22 A / AC-22 B	800/800	1000/1000	1250/1250	1600/1600	-/2000	-/2500	-/3200
415 VAC	AC-23 A / AC-23 B	800/800	1000/1000	1250/1250	1600/1600	-/1600	-/1600	-/1600
500 VAC	AC-20 A / AC-20 B	800/800	1000/1000	1250/1250	1600/1600	2000/2000	2500/2500	3200/3200
500 VAC	AC-21 A / AC-21 B	800/800	1000/1000	1250/1250	1600/1600	-/2000	-/2500	-/3200
500 VAC	AC-22 A / AC-22 B	630/630	800/800	1000/1000	1000/1000			
500 VAC	AC-23 A / AC-23 B	400/400	630/630	800/800	800/800			
690 VAC	AC-20 A / AC-20 B	800/800	1000/1000	1250/1250	1600/1600	2000/2000	2500/2500	3200/3200
690 VAC	AC-21 A / AC-21 B	800/800	1000/1000	1250/1250	1600/1600	-/2000	-/2500	-/3200
690 VAC	AC-22 A / AC-22 B	630/630	800/800	1000/1000	1600/1600			
690 VAC	AC-23 A / AC-23 B	400/400	630/630	800/800	1000/1000			
220 VDC	DC-20 A / DC-20 B	800/800	1000/1000	1250/1250	1600/1600			
220 VDC	DC-21 A / DC-21 B	800/800	1000/1000	1250/1250	1250/1250			
220 VDC	DC-22 A / DC-22 B	800/800	1000/1000	1250/1250	1250/1250			
220 VDC	DC-23 A / DC-23 B	800/800	1000/1000	1250/1250	1250/1250			
440 VDC	DC-20 A / DC-20 B	800/800	1000/1000	1250/1250	1600/1600			
440 VDC	DC-21 A / DC-21 B	800/800 <sup>(3)</sup>	1000/1000 <sup>(3)</sup>	1250/1250 <sup>(3)</sup>	1250/1250 <sup>(3)</sup>			
440 VDC	DC-22 A / DC-22 B	800/800 <sup>(3)</sup>	1000/1000 <sup>(3)</sup>	1250/1250 <sup>(3)</sup>	1250/1250 <sup>(3)</sup>			
440 VDC	DC-23 A / DC-23 B	800/800 <sup>(3)</sup>	1000/1000 <sup>(3)</sup>	1250/1250 <sup>(3)</sup>	1250/1250 <sup>(3)</sup>			

Rated operational currents  $I_e$  (A) according to IEC 60947-6-1

Rated voltage	Utilisation category	800	1000	1250	1600	2000	2500	3200
415 VAC	AC-31 B	800	1000	1250	1600	2000	2500	3200
415 VAC	AC-32 B	800	1000	1250	1600	2000	2000	2000
415 VAC	AC-33 B	800	800	800	1000	1250	1250	1250

Fuse protected short-circuit withstand as per IEC 60947-3 at 415 VAC

Prospective short-circuit current (kA rms)	50	100	100	100				
Associated fuse rating (A)	800	1000	1250	2x800				

Circuit breaker protected short-circuit withstand with any circuit breaker that ensures tripping in less than 0.3s<sup>(4)</sup>

Rated short-time withstand current 0.3s low (kA rms)	47	64	64	78	78	78	78	78
--	----	----	----	----	----	----	----	----

Short-circuit withstand without protection as per IEC 60947-3 at 415 VAC

Rated short-time withstand current 1s low (kA rms)	26	35	35	50	50	50	50	50
Rated short-circuit making capacity	48	73.5	73.5	110	110	110	110	110

Short-circuit withstand without protection as per IEC 60947-6-1 at 415 VAC

Rated short-time withstand current 60ms low (kA rms)	16	20	25	32	40	50	50	50
--	----	----	----	----	----	----	----	----

Connection

Maximum Cu cable cross-section (mm <sup>2</sup> )	2 x 185	2 x 240						
Minimum Cu busbar cross-section (mm <sup>2</sup> )	2 x 40 x 5	2 x 50 x 5	2 x 60 x 5	2 x 80 x 5	2 x 100 x 10	2 x 100 x 10	2 x 100 x 10	
Maximum Cu cable cross-section (mm <sup>2</sup> )	2 x 300	4 x 185	4 x 185	6 x 185				
Maximum Cu busbar width (mm)	63	63	63	100	100	100	100	
Tightening torque mini / maxi (Nm)	20/26	20/26	20/26	40/45	40/45	40/45	40/45	

Switching time (Standard setting)

I-II or II-I (s)	2.6	2.6	2.6	2.6	2	2	2	
I-0 or 0-II (s)	1.6	1.6	1.6	1.6	1	1	1	
Duration of "electrical blackout" I - II (s) minimum	1.5	1.5	1.5	1.6	1	1	1	

Power supply

min / max (VAC)	166/332	166/332	166/332	166/332	166/332	166/332	166/332	
-----------------	---------	---------	---------	---------	---------	---------	---------	--

Control supply power demand

Power supply 230 VAC inrush / nominal (VA) - ATyS	460/184	460/184	460/184	460/230	812/322	812/322	812/322	
Power supply 230 VAC inrush / nominal (VA) - ATyS d, t, g, p	482/206	482/206	482/206	482/252	834/344	834/344	834/344	

Mechanical characteristics

Durability (number of operating cycles)	4 000	4 000	4 000	3 000	3 000	3 000	3 000	
Weight ATyS 3 P (kg)	27.9	28.4	28.9	33.1	50.7	50.7	61.0	
Weight ATyS 4 P (kg)	32.2	32.9	33.6	39.4	61.6	61.6	75.3	
Weight ATyS d 3 P (kg)	28.5	29.0	29.5	33.7	51.3	51.3	61.6	
Weight ATyS d 4 P (kg)	32.8	33.5	34.2	40.0	62.2	62.2	75.9	
Weight ATyS t, g, p 3 P (kg)	29.0	29.5	30.0	34.2	51.8	51.8	62.1	
Weight ATyS t, g, p 4 P (kg)	33.3	34.0	34.7	40.5	62.7	62.7	76.4	

(1) Category with index A = frequent operation - Category with index B = infrequent operation.

(2) 3-pole device with 2 poles in series for the "+" and 1 pole for the "-".

(3) 4-pole device with 2 poles in series by polarity.

(4) Value for coordination with any circuit breaker that ensures tripping in less than 0.3s.

For coordination with specific circuit-breaker references, higher short-circuit current values are available. Please consult us.

## 10. PREVENTIVE MAINTENANCE

It is recommended to verify the tightening torque of all connections and to operate the product in a full operating cycle (I – 0 – II – 0 – I: Auto and Manual) at least once a year.

## 11. TROUBLE SHOOTING GUIDE

<p>The ATyS d does not operate electrically</p>	<ul style="list-style-type: none"> <li>• Verify the power supply on terminals 101-102 and 201-202: 208 - 277 Vac <math>\pm</math>20 %</li> <li>• Verify that the front selector switch is in position (AUT)</li> <li>• Verify that contacts 313 and 317 are open.</li> <li>• Verify that the power LED (Green) is On whilst the fault LED (RED) is off.</li> <li>• Verify presence of at least one green LED on the DPS module.</li> <li>• Verify that the product is available with contacts 63A and 64A closed.</li> </ul>
<p>It is not possible to manually operate the switch</p>	<ul style="list-style-type: none"> <li>• Verify that the front selector switch position is on the Manual position.</li> <li>• Make sure that the product is not padlocked</li> <li>• Verify the rotation direction of the handle</li> <li>• Apply a sufficient progressive action in the direction as indicated on the handle.</li> </ul>
<p>Electrical operation does not correspond to external order I,O,II</p>	<ul style="list-style-type: none"> <li>• Verify the selected control logic wiring (impulse or contactor)</li> <li>• Verify the connector connections.</li> </ul>
<p>The fault/manual LED is ON</p>	<ul style="list-style-type: none"> <li>• The FAULT / MANUAL LED is on when in manual mode (this is normal) and in AUT Mode when there is an internal fault in the ATyS d. To reset a fault condition switch the ATyS d from AUT to Manu and back to AUT. Should the fault LED remain on you will need to localize and clear the fault prior to reset.</li> <li>• The FAULT / Manual LED will also be on when contact 313 is closed with 317. (Force the ATyS d to off position). This is a normal condition.</li> <li>• Should the Fault LED remain on abnormally, contact SOCOMEC.</li> </ul>
<p>Impossible to padlock</p>	<ul style="list-style-type: none"> <li>• Verify that the front selector switch is in manual position</li> <li>• Verify that the emergency handle for manual operation is not inserted into the ATyS d manual slot.</li> <li>• Verify that the ATyS d is in 0 position (Padlocking is only possible in 0 position for standard products)</li> </ul>

## 12. ACCESSORIES: ordering information

### 12.1. Terminal shrouds

#### Use

IP2X protection against direct contact with terminals or connecting parts.

#### Advantages

Perforations allow remote thermographic inspection without the need to remove the shrouds.

Rating (A)	No. of poles	Position	Reference
125 ... 200	3 P	top / bottom / front (I) / rear (II)	2694 <b>3014</b> <sup>(1)(2)</sup>
125 ... 200	4 P	top / bottom / front (I) / rear (II)	2694 <b>4014</b> <sup>(1)(2)</sup>
250 ... 400	3 P	top / bottom / front (I) / rear (II)	2694 <b>3021</b> <sup>(1)(2)</sup>
250 ... 400	4 P	top / bottom / front (I) / rear (II)	2694 <b>4021</b> <sup>(1)(2)</sup>
500 ... 630	3 P	top / bottom / front (I) / rear (II)	2694 <b>3051</b> <sup>(1)(2)</sup>
500 ... 630	4 P	top / bottom / front (I) / rear (II)	2694 <b>4051</b> <sup>(1)(2)</sup>

(1) To shroud front switch top and bottom 2 references required.

(2) To fully shroud front, rear, top and bottom 4 references required.



access\_2016\_a\_2\_cat

ENGLISH

### 12.2. Terminal screens

#### Use

Top and bottom protection against direct contact with terminals or connection parts.

For upstream and downstream protection, order the reference once.

Rating (A)	No. of poles	Position	Reference
125 ... 200	3 P	top / bottom	1509 <b>3012</b>
125 ... 200	4 P	top / bottom	1509 <b>4012</b>
250 ... 400	3 P	top / bottom	1509 <b>3025</b>
250 ... 400	4 P	top / bottom	1509 <b>4025</b>
500 ... 630	3 P	top / bottom	1509 <b>3063</b>
500 ... 630	4 P	top / bottom	1509 <b>4063</b>
800 ... 1250	3 P	top / bottom	1509 <b>3080</b>
800 ... 1250	4 P	top / bottom	1509 <b>4080</b>
1600 ... 1600	3 P	top / bottom	1509 <b>3160</b>
1600 ... 1600	4 P	top / bottom	1509 <b>4160</b>
2000 ... 3200	3 P	top / bottom	1509 <b>3200</b>
2000 ... 3200	4 P	top / bottom	1509 <b>4200</b>



access\_207\_a\_2\_cat

### 12.3. Bridging bars

#### Use

For bridging power terminals on the top or bottom side of the switch. One piece required per pole.

Rating (A)	Section (mm)	Reference
125 ... 200	20 x 2,5	4109 <b>0019</b>
250	25 x 2,5	4109 <b>0025</b>
400	32 x 5	4109 <b>0039</b>
500	32 x 5	4109 <b>0050</b>
630	50 x 5	4109 <b>0063</b>
800 ... 1000	50 x 6	4109 <b>0080</b>
1250	60 x 8	4109 <b>0120</b>
1600 ... 1600	90 x 10	4109 <b>0160</b>

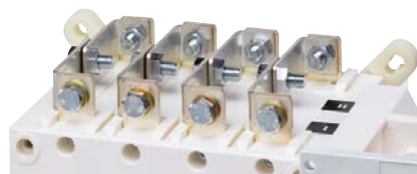

access\_205\_a\_2\_cat

## 12.4. Power terminal connection kits

Details: refer to page 24.

### Use

Enables:

- connection between the two power terminals of the same pole for 2000 to 3200 A ratings (Fig. 1 and Fig 2).
  - top or bottom bridging connection (Fig. 3).
- For 3200 A rating, the connection pieces (part A) are delivered bridged from factory.

Bolt sets must be ordered separately. The technical notice for these specific accessories can be downloaded from [www.socomec.com](http://www.socomec.com).

Fig. 1

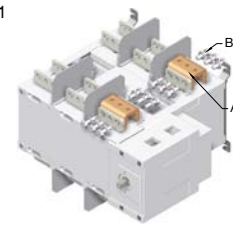

access\_226\_b\_1\_x\_cat

access\_232\_a\_1\_cat

access\_228\_b\_1\_x\_cat

access\_233\_a\_1\_cat

access\_230\_b\_1\_x\_cat

access\_234\_a\_1\_cat

Top or bottom flat connection - Fig. 1			
Rating (A)	Piece	Quantity to order per pole <sup>(1)</sup>	Reference
2000 ... 2500	Connection - part A	2	2619 1200
2000 ... 2500	Bolt set - part B	2	2699 1200
3200	Connection - part A		included
3200	Bolt set - part B	2	2699 1200

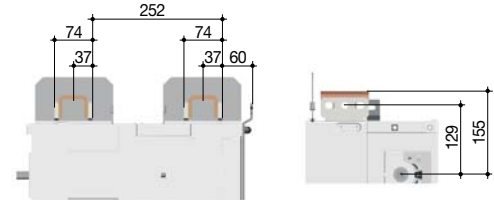
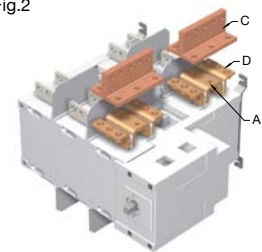

Fig.2



Top or bottom edgewise connection - Fig. 2			
Rating (A)	Piece	Quantity to order per pole <sup>(1)</sup>	Reference
2000 ... 2500	Connection - part A	2	2619 1200
2000 ... 2500	T piece - part C	2	2629 1200 <sup>(2)</sup>
2000 ... 2500	Bracket- part D	2	2639 1200 <sup>(2)</sup>
3200	Connection - part A		included
3200	T piece - part C	2	2629 1200 <sup>(2)</sup>
3200	Bracket- part D	2	2639 1200 <sup>(2)</sup>

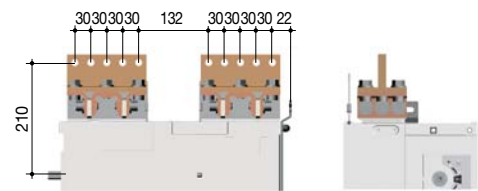
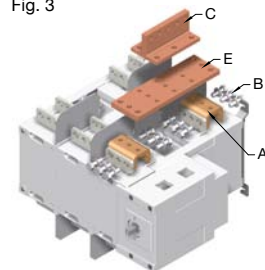
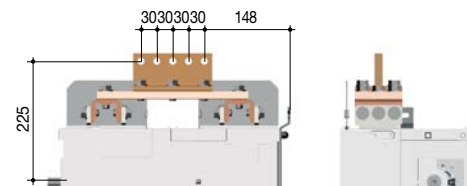

Fig. 3



Top or bottom bridging connection - Fig. 3			
Rating (A)	Piece	Quantity to order per pole <sup>(1)</sup>	Reference
2000 ... 2500	Connection - part A	2	2619 1200
2000 ... 2500	Bolt set - part B	2	2699 1200
2000 ... 2500	Bar - part E	1	4109 0250 <sup>(2)</sup>
2000 ... 2500	T piece - part C	1	2629 1200 <sup>(2)</sup>
3200	Connection - part A		included
3200	Bolt set - part B	2	2699 1200
3200	Bar - part E	1	4109 0320 <sup>(2)</sup>
3200	T piece - part C	1	2629 1200 <sup>(2)</sup>

(1) Example for 3 pole device equipped upstream only: Order 3 times the indicated quantities.  
 (2) Bolt set is provided with the accessories.



## 12.5. Control voltage transformer

### Use

For applications without neutral, this autotransformer provides the 230 VAC required to power these ATyS d products.

Rating (A)	Reference
125 ... 3200	1599 4064

## 12.6. Phase failure device

### Use

The ATyS DS is a voltage relay for monitoring a single three-phase power supply source.

Upon failure of the power supply source, the voltage relay's fault contact closes.

This output can be utilised, for example, to order the transfer of an ATyS motorised changeover switch.



atys\_762\_a\_1\_cat

Rating (A)	Reference
ATyS DS	192X 0056

## 12.7. Door escutcheon plate

### Use

When direct access to the ATyS front face (mode selection, manual operation, display...) is required, the door surround can be utilised to provide a clean and safe finish to the panel's cut-out.

Rating (A)	Reference
125 ... 630	1539 0012
800 ... 3200	1539 0080



atys\_595\_a\_2\_cat

## 12.8. Mounting spacers

### Use

Increases the distance between the rear power terminals and the backplate by 10 mm.

This accessory may also be used to replace the original mounting spacers.

Rating (A)	Description of accessory	Reference
125 ... 630	1 set of 2 spacers	1509 0001



atys\_009\_a\_2\_cat

## 12.9. ATyS C30 / C40 ATS Controllers

ATyS C30 and C40 devices are modular, din rail mounted ATS controllers designed for use with products such as the ATyS d

motorised changeover switch. For further details refer to the SOCOMEC General Catalogue.

Type	ATyS C30 Reference	ATyS C40 Reference
Supplied from measurement circuit	1599 3030	
DC power supply	1599 3031	1599 3040



ATyS\_448.B

## 12.10. Remote display and control units

The Remote display unit type ATyS D10 is designed to be a plug and play solution connected directly to the ATyS d through an RJ 45 cable. The ATyS D20 Control unit may be used with the ATyS d when associated with an ATyS C30 or C40 controller only

### Use

To display source availability and position indication on the front of a panel.

Interfaces are powered from the ATyS changeover switch, via the RJ45 connection cable.

Maximum connection distance: 3 m.

### ATyS D10 for ATyS d

To display source availability and position indication on the front panel of an enclosure. Protection degree: IP21.

### ATyS D20 - for ATyS p

The D20 displays position measurements and enables ATyS p mode control and configuration from the front of a panel.

Protection degree: IP21.

### Door mounting

2 holes Ø 22.5. ATyS changeover switch connection via RJ45 cable, not isolated.

Cable available as an accessory.

Interfaces are powered from the ATyS.

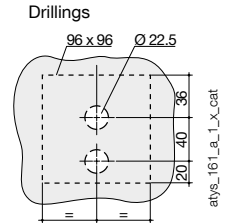

Description of accessories	Reference
ATyS D10	9599 2010
ATyS D20	9599 2020

## 12.11. Communication cable

### Use

To connect between a remote interface (type D10 or D20) and an ATyS changeover switch (ATyS d, t, g or p).

### Characteristics

RJ45 8 wire straight-through, non isolated cable. Length 3m.

For ATyS d, t, g and p		
Type	Length	Reference
RJ45 cable	3 m	1599 2009



## 12.12. DC power supply

### Use

Allows an ATyS to be supplied from a 12 or 24 VDC source.

To be positioned as close as possible to the DC power supply source.

Rating (A)	Operating voltage	Reference
125 ... 1600	12 VDC / 230 VAC	1599 5012
125 ... 1600	24 VDC / 230 VAC	1599 5112

## 13. FACTORY FITTED ACCESSORIES

### 13.1. Additional auxiliary contacts

#### Use

Pre-breaking and signalling of positions I and II. Each reference provides a single factory fitted NO/NC contact for both positions.

Low level auxiliary contacts: Please consult us. If additional auxiliary contacts are required please consult us.



access\_0165\_a\_1\_cat

Rating (A)	Nominal current (A)	Operating current I <sub>o</sub> (A)			
		A - 250 13 VAC	400 VAC AC-13	24 VDC DC-13	48 VDC DC-13
125 ... 3200	16	12	8	14	6

Rating (A)	Reference
125 ... 630	1599 0002 <sup>(1)</sup>
800 ... 1600	1599 0032 <sup>(1)</sup>
2000 ... 3200	included

(1) Up to 2 auxiliary contacts can be ordered.

### 13.2. Padlocking in all 3 positions I – 0 - II

#### Use

Enables the ATyS to be padlocked in positions 0, I and II (factory fitted).

Rating (A)	Reference
125 ... 630	1599 0003
800 ... 3200	1599 0004



### 13.3. Padlocking with RONIS type accessories

#### Use

With the product in manual mode, it enables locking in position 0 using a RONIS EL1 1AP lock (factory fitted).

Locking in all three positions (I-0-II) requires, in addition, the "3 position padlocking" accessory.

Rating (A)	Reference
125 ... 630	1509 1006
800 ... 3200	1509 1004

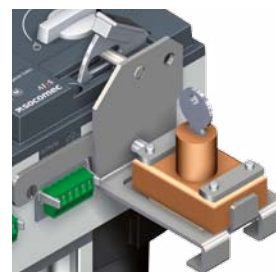

# 14. ATyS Family: ORDERING INFORMATION

The following is an ordering guide for ATyS Motorised Changeover Switches delivered inclusive of the emergency handle and storage clip. This guide is intended so as to explain the logic behind SOCOMEC ATyS reference numbers.

When ordering please consult the latest SOCOMEC catalogue.

## Typical ATyS reference

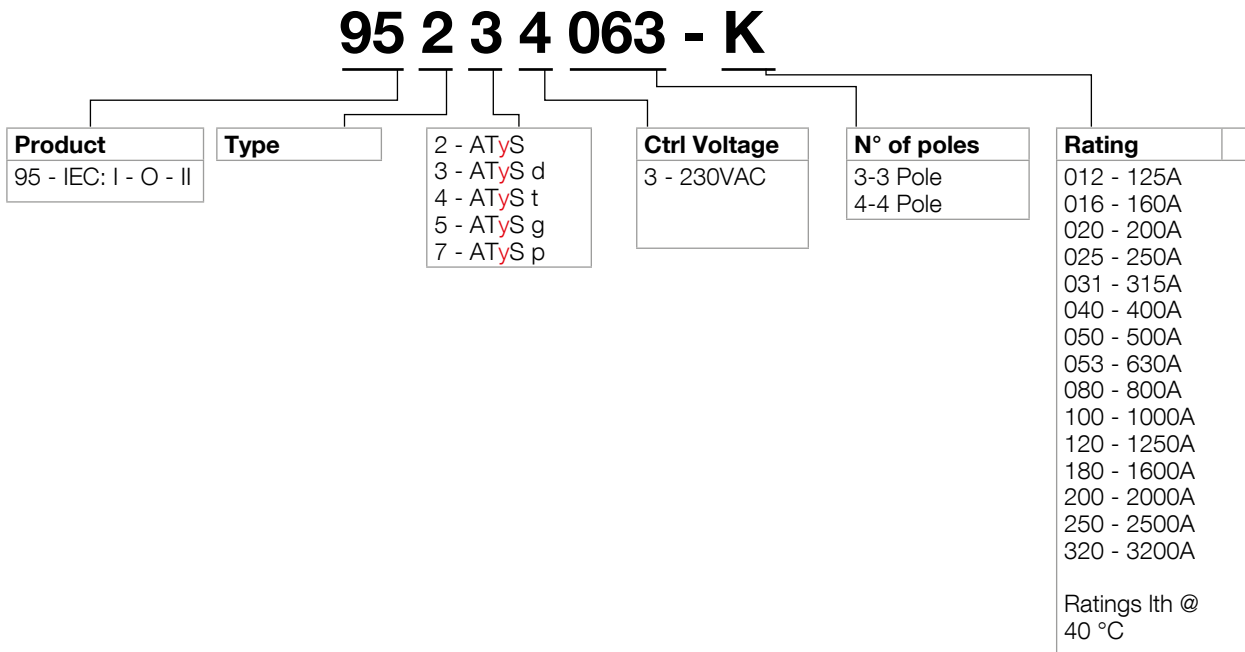

**Note:**

\* When a key selector switch is required add - K at the end of standard 8 digit reference number.





# Socomec worldwide

## IN WESTERN EUROPE

### BELGIUM

B - 1070 Bruxelles  
Tel. +32 2 340 02 30  
info.be@socomec.com

### FRANCE

F - 94132 Fontenay-sous-Bois Cedex  
Tel. +33 1 45 14 63 30  
info.scp.fr@socomec.com

### GERMANY

D - 76275 Ettlingen  
Tel. +49 7243 65292 0  
info.scp.de@socomec.com

### ITALY

I - 20098 San Giuliano Milanese (MI)  
Tel. +39 02 98 49 821  
info.scp.it@socomec.com

### NETHERLANDS

NL - 3991 CD Houten  
Tel. +31 30 760 0900  
info.nl@socomec.com

### SPAIN

E - 08329 Teià (Barcelona)  
Tel. +34 93 540 75 75  
info.es@socomec.com

### UNITED KINGDOM

Hitchin Hertfordshire SG4 0TY  
Tel. +44 1462 440 033  
info.scp.uk@socomec.com

## IN EASTERN EUROPE, MIDDLE EAST, AFRICA

### POLAND

01-625 Warszawa  
Tel. +48 91 442 64 11  
info.scp.pl@socomec.com

### ROMANIA

023883 Bucharest  
Tel. +40 21 319 36 88  
info.ro@socomec.com

### RUSSIA

125167 - Moscow  
Tel. +7 495 775 19 85  
info.ru@socomec.com

### SLOVENIA

SI - 1000 Ljubljana  
Tel. +386 1 5807 860  
info.si@socomec.com

### TURKEY

34775 Istanbul  
Tel. +90 216 540 71 20-21-22  
info.tr@socomec.com

### UNITED ARAB EMIRATES

Dubai, U.A.E.  
Tel. +971 4 29 98 441  
info.ae@socomec.com

## IN ASIA

### CHINA

P.R.C 200052 Shanghai - China  
Tel. +86 21 52 98 95 55  
info.cn@socomec.com

### INDIA

122001 Gurgaon, Haryana - India  
Tel. +91 124 4027210  
info.scp.in@socomec.com

### SINGAPORE

Singapore 408723  
Tel. +65 6506 7600  
info.sg@socomec.com

## IN NORTH AMERICA

### USA, CANADA & MEXICO

Cambridge, MA 02142 USA  
Tel. +1 617 245 0447  
info.us@socomec.com

## HEAD OFFICE

### SOCOMEK GROUP

S.A. SOCOMEK capital 10 816 800 €  
R.C.S. Strasbourg B 548 500 149  
B.P. 60010 - 1, rue de Westhouse  
F-67235 Benfeld Cedex - FRANCE



[www.socomec.com](http://www.socomec.com)

## INTERNATIONAL SALES DEPARTMENT

### SOCOMEK

1, rue de Westhouse - B.P. 60010  
F - 67235 Benfeld Cedex - FRANCE  
Tel. +33 (0)3 88 57 41 41  
Fax +33 (0)3 88 74 08 00  
info.scp.isd@socomec.com

## YOUR DISTRIBUTOR

