

**INSTRUCTION
MANUAL**

DIRIS B-10 & B-30

Multifunction meters and associated
current sensors

EN

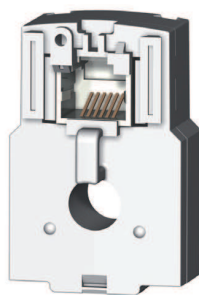
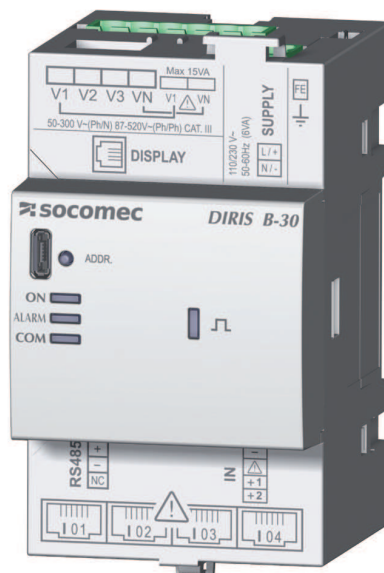
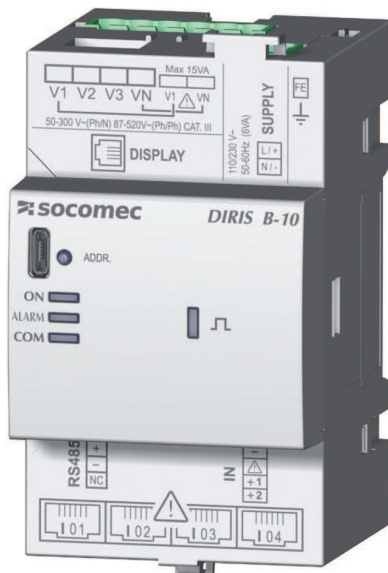

[www.socomec.com/
en/diris-b](http://www.socomec.com/en/diris-b)

1. TABLE OF CONTENTS

- 1. DOCUMENTATION** 4
- 2. HAZARDS AND WARNINGS** 5
 - 2.1. Risk of electrocution, burns or explosion 5
 - 2.2. Risk of damaging the unit 5
 - 2.3. Liability 6
- 3. PRELIMINARY OPERATIONS** 7
- 4. INTRODUCTION** 8
 - 4.1. Introduction to the DIRIS B 8
 - 4.1.1. Range 8
 - 4.1.2. Functions 8
 - 4.1.3. Electrical values measured 10
 - 4.1.4. Dimensions 11
 - 4.2. Presentation of optional modules 12
 - 4.2.1. Range 12
 - 4.2.2. Dimensions 12
 - 4.3. Presentation of associated current sensors 13
 - 4.3.1. TE solid-core current sensors 14
 - 4.3.2. TR split-core current sensors 16
 - 4.3.3. TF flexible current sensors 17
 - 4.3.4. Adapters for 5A sensors 18
- 5. MOUNTING** 19
 - 5.1. Recommendations and safety 19
 - 5.2. Installing the DIRIS B 19
 - 5.2.1. DIN rail mounting 19
 - 5.2.2. Plate mounting 19
 - 5.2.3. Sealing accessory for sensors 20
 - 5.3. Installing the optional modules 20
 - 5.3.1. Installing an optional module on DIRIS B 20
 - 5.3.2. Installing an optional module on an optional module 20
 - 5.4. Installing TE solid-core sensors 21
 - 5.4.1. Mounting accessories 21
 - 5.4.2. DIN rail mounting 21
 - 5.4.3. Plate mounting 23
 - 5.4.4. Installing on a cable with clamping collar 25
 - 5.4.5. Bar mounting 26
 - 5.4.6. Sensors assembly 27
 - 5.4.7. Sealing accessories for sensors 27
 - 5.5. Installing TR split-core sensors 28
 - 5.5.1. Cable mounting 28
 - 5.6. stranded sensors TE mounting 28
 - 5.6.1. Installing the casing 28
 - 5.6.2. Cable mounting 29
 - 5.6.3. Bar mounting 29
 - 5.7. Installing the 5A adapter 29
- 6. CONNECTION** 30
 - 6.1. Connecting the DIRIS B 30
 - 6.2. Connecting the optional modules 32
 - 6.2.1. Input/output modules 32
 - 6.2.2. Communication modules 33
 - 6.3. Connecting the current sensors 34
 - 6.3.1. Connection concept 34
 - 6.3.2. Details of the RJ12 connections for each current sensor 34

6.3.3. Connecting to the electrical network and loads	35
6.3.4. Connection of the functional earth.	37
7. STATUS AND AUTO-ADDRESSING LEDS	38
7.1. Status LEDs	38
7.2. Auto-addressing.	38
8. COMMUNICATION.	40
8.1. General information	40
8.2. RS485 rules	40
8.3. Radio-frequency (RF) rules.	41
8.3.1. Installation	42
8.3.2. EC Declaration of Conformity	42
8.4. Communication tables	42
9. CONFIGURATION	43
9.1. Configuration using Easy Config	43
9.1.1. Connection modes	43
9.1.2. Using Easy Config.	45
9.1.3. Synchronisation of products	47
9.2. Configuration from the DIRIS D-30 remote display.	48
9.2.1. Connection mode	48
10. ALARMS.	49
10.1. Alarms upon events	49
10.1.1. Electrical parameters.	49
10.1.2. Voltage and current unbalance (in a three-phase network)	49
10.1.3. EN 50160 voltage quality events.	50
10.1.4. Consumption	50
10.1.5. Analogue inputs	50
10.1.6. Digital inputs	50
10.1.7. Combination of alarms	50
10.2. Setup alarms	51
10.2.1. Current/voltage compatibility	51
10.2.2. Incorrect direction of rotation (three-phase network)	51
10.2.3. Faulty current sensor.	51
10.3. Setting up alarms	51
10.3.1. ALARM LED on front.	51
10.3.2. Activation of an output	51
10.3.3. Activation of an input.	51
10.3.4. RS485 Modbus.	52
10.3.5. Display and WEBVIEW	52
11. FEATURES	53
11.1. DIRIS B features.	53
11.1.1. Mechanical features	53
11.1.2. Electrical specifications	53
11.1.3. Input characteristics	53
11.1.4. Measuring characteristics	53
11.1.5. Communication specifications.	54
11.1.6. Environmental specifications	54
11.1.7. Electromagnetic compatibility	55
11.1.8. Safety	55
11.1.9. Service life.	55
11.2. DIRIS O optional modules characteristics	55
11.3. DIRIS D-30 display characteristics	57
11.3.1. Mechanical features	57
11.3.2. Single product connection	57
11.3.3. Electrical specifications	57
11.3.4. Environmental specifications	57
11.4. TE, TR and RF sensor features	58
12. PERFORMANCE CLASSES.	60
12.1. Specification of the characteristics	60
12.2. Evaluation of the power supply quality	61

1. DOCUMENTATION

All documentation relating to DIRIS B units and their associated sensors is available on the SOCOMEC website at the following address:

www.socomec.com/en/diris-b





2. HAZARDS AND WARNINGS

The term "unit" used in the following paragraphs encompasses the DIRIS B, its optional modules and its associated current sensors (TE, TR or TF).

The assembly, use, servicing and maintenance of this equipment must only be carried out by trained, qualified professionals.

SOCOMECC shall not be held responsible for failure to comply with the instructions in this manual.

2.1. Risk of electrocution, burns or explosion



	Caution: risk of electric shock	Ref. ISO 7000-0434B (2004-01)
	Caution Refer to the accompanying documentation each time this symbol is shown	Ref. ISO 7000-0434B (2004-01)

- This device must only be installed and serviced by qualified personnel who have in-depth knowledge of installing, commissioning and operating the device and who have had appropriate training. He or she should have read and understood the various safety measures and warnings stated in the instructions.
- Prior to any work on or in the unit, isolate the unit's voltage inputs and auxiliary power supplies.
- Always use an appropriate voltage detection device to confirm the absence of voltage.
- Replace all devices, doors and covers before turning on power to this equipment.
- Always power the device with the correct rated voltage.
- Install the unit following the recommended installation instructions and in a suitable electrical cabinet.
- Always connect the TE, TR or TF current sensors using the recommended connection cables and observing the maximum prescribed currents.

	Do NOT clamp or pull out NON-INSULATED conductors carrying DANGEROUS VOLTAGE which could cause an electric shock, burn or arc flash. Ref. IEC 61010-2-032
---	--

Failure to take these precautions could cause death or serious injuries.

2.2. Risk of damaging the unit

	Caution: risk of electric shock	Ref. ISO 7000-0434B (2004-01)
	Caution Refer to the accompanying documentation each time this symbol is shown	Ref. ISO 7000-0434B (2004-01)

To ensure that the unit operates correctly, make sure that:

- The unit is correctly installed.
- The auxiliary power supply voltage indicated on the product is observed: 110 V - 230 VAC ($\pm 15\%$).
- The network frequency indicated on the device is observed: 50 or 60 Hz.
- A maximum voltage at the voltage input terminals of 520 VAC phase/phase or 300 VAC phase/neutral is observed.
- Always connect the TE, TR or TF current sensors using the recommended connection cables and observing the maximum prescribed currents.

Failure to respect these precautions could cause damage to the unit.

2.3. Liability

- Assembly, connection and use must be carried out in accordance with the installation standards currently in force.
- The unit must be installed in accordance with the rules given in this manual.
- Failure to observe the rules for installing this unit may compromise the device's intrinsic protection.
- The unit must be positioned within an installation which complies with the standards currently in force.
- Any cables which need to be replaced may only be replaced with cables with the correct ratings.

3. PRELIMINARY OPERATIONS

To ensure the safety of personnel and the product, please carefully read the contents of these instructions before installation.

Check the following points as soon as you receive the package containing the unit, one or several sensors:

- The packaging is in good condition
- The unit has not been damaged during transportation
- The device reference conforms to your order
- The packaging includes the unit fitted with removable terminal blocks and a Quick start guide.

4. INTRODUCTION

4.1. Introduction to the DIRIS B

The DIRIS B is a compact PMD* with a modular format. It is designed for measuring, monitoring and reporting electrical energy. The DIRIS B offers a range of functions for measuring voltage, current, power, energy and quality. It can be used to jointly analyse the single-phase and three-phase loads. Add optional modules to manage multi-fluid energy sources (water, gas, etc.) and additional inputs/outputs.

The connection mode for the current sensors allows quick, easy installation. Their automatic identification (type and rating) by the DIRIS B significantly reduces the risk of errors during installation. This approach, based on combining the sensor with the DIRIS B, also means the overall accuracy of the DIRIS B + current sensor measurement chain can be guaranteed for all values measured.



The product is configured from its remote display or via the Easy Config software. The measurements can be accessed via the WEBVIEW web server, available on the G-30, G-40, G-50 and G-60 communication gateways, enabling monitoring of the electrical values (Power Monitoring version) and reporting of the energy data (Power & Energy Monitoring version). The data can also be accessed via the HYPERVIEW energy management software.

The communication modes RS485 Modbus or radio frequency are available depending on the DIRIS B reference. You can extend the range of communication modes (RS485, PROFIBUS, BACnet) by adding optional modules.

The DIRIS B can be integrated as a standalone solution or in a multi-product configuration within an energy management system.

*PMD: Performance Measuring and Monitoring Device in accordance with IEC 61557-12.

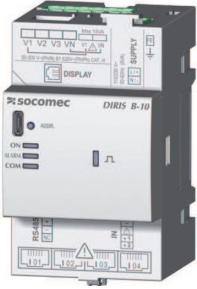
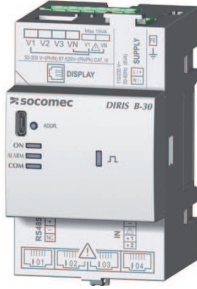
4.1.1. Range

				
	PMD	DIRIS B-10	DIRIS B-30 RS	DIRIS B-30 RF
Communication	RS485	•	•	
	RF			•
		Ref. 4829 0010	Ref. 4829 0000	Ref. 4829 0002

Accessories

Remote antenna RF 868MHz Height: 210mm	Cable for remote antenna. SMA connector. Length: 3m	Sealing kit. To secure terminals U / I	USB cable for configuration
Ref. 4854 0126	Ref. 4854 0127	Ref. 4829 0049	Ref. 4829 0050

4.1.2. Functions

The DIRIS B boasts numerous functions, including:

- **General measurements**

- Current, frequency, voltage electrical values
 - Power, power factor, cos phi and tan phi
 - Operation across 4 quadrants
 - Predictive power
 - Overall accuracy of the DIRIS B + sensors measurement chain guaranteed up to class 0.5 (depending on the current sensor used) for active energy and power in accordance with IEC 61557-12
- **Quality**
 - Current, phase to neutral voltage, phase to phase voltage
 - THD and harmonics up to order 63 for voltage and current
 - Voltage and current crest factor (*)
 - Current and voltage imbalance
 - EN50160 events (Uswl, Udip, Uint) and current overloads (*)
 - **Data logging**
 - Recording of average electrical values
 - Recording and timestamping of min/max electrical values
 - **Metering**
 - Partial and total apparent, reactive and active power
 - Load curves (*)
 - Multi-tariff
 - **Alarm (*)**
 - 25 timestamped alarms with boolean combination
 - **Connection**
 - 4 current inputs with automatic recognition of the current sensors via a quick connection cable (RJ12 type)
 - Simultaneous management of several single-phase, two-phase and three-phase loads
 - Checking of the connection, detection of the current sensors and auto-configuration of the networks
 - Guarantees the overall accuracy of the DIRIS B + sensor measurement chain in terms of power and active energy as per IEC 61557-12
 - **Inputs / Outputs**
 - 2 logical inputs
 - Optional extension module for logical, analogue and temperature inputs/outputs

Communication

- RS485 or radio frequency (RF) communication (see reference)
- Optional communication module (RS485, PROFIBUS, BACnet)
- Connects to a DIRIS D-30 remote display via RJ9 or D-50 / D-70 via RS485
- Integration in the gateway's WEBVIEW web server for multi-product applications
- Time synchronisation with the gateway
- Auto-addressing in association with the gateway

(*) Available only on the DIRIS B-30 RS (ref. 4829 0000) and DIRIS B-30 RF (ref. 4829 0002)

4.1.3. Electrical values measured

		DIRIS B-10	DIRIS B-30 RS / RF
General	Instant with timestamped Min/Max & Average with timestamped Min/Max		
Phase Voltage - Neutral	V1, V2, V3, VN, Vsystem (without min/max)	•	•
Phase to phase voltage	U12, U23, U31, Usystem (without min/max)	•	•
Frequency	f	•	•
Current	I1, I2, I3, IN, Isystem (without min/max)	•	•
Total power and power by phase	P, Q, S, P1, P2, P3, Q1, Q2, Q3, S1, S2, S3	•	•
Predictive power	P, Q, S	•	•
Total power factor and power factor by phase	PF, PF1, PF2, PF3	•	•
Cos phi and tan phi	L1, L2, L3 (instantaneous values)	•	•
Quality Instant & Average			
Phase to neutral voltage unbalance	Vdir, Vinv, Vhom, Vnba, Vnb	•	•
Phase to phase voltage unbalance	Udir, Uinv, Unba, Unb	•	•
Current unbalance	Idir, linv, lhom, Inba, Inb	•	•
Phase to neutral voltage THD	THDv1, THDv2, THDv3, THD Vsys	•	•
Phase to phase voltage THD	THDu12, THDu23, THDu31, THD Usys	•	•
Current THD	THDi1, THDi2, THDi3, THDiN, THD Isys	•	•
THD system	THD V, THD U, THD I	•	•
Phase to neutral voltage harmonics orders 1 to 63	V1h, V2h, V3h		•
Phase to phase voltage harmonics orders 1 to 63	U12h, U23h, U31h		•
Current harmonics orders 1 to 63	I1h, I2h, I3h, INh		•
Crest Factor	V1, V2, V3, U12, U23, U31, I1, I2, I3, In		•
Energies			
Total energy	Ea+, Ea-, Er+ (total, lagging, leading), Er- (total, lagging, leading), Eap	•	•
Partial energy	Ea+, Ea-, Er+, Er-, Eap	•	•

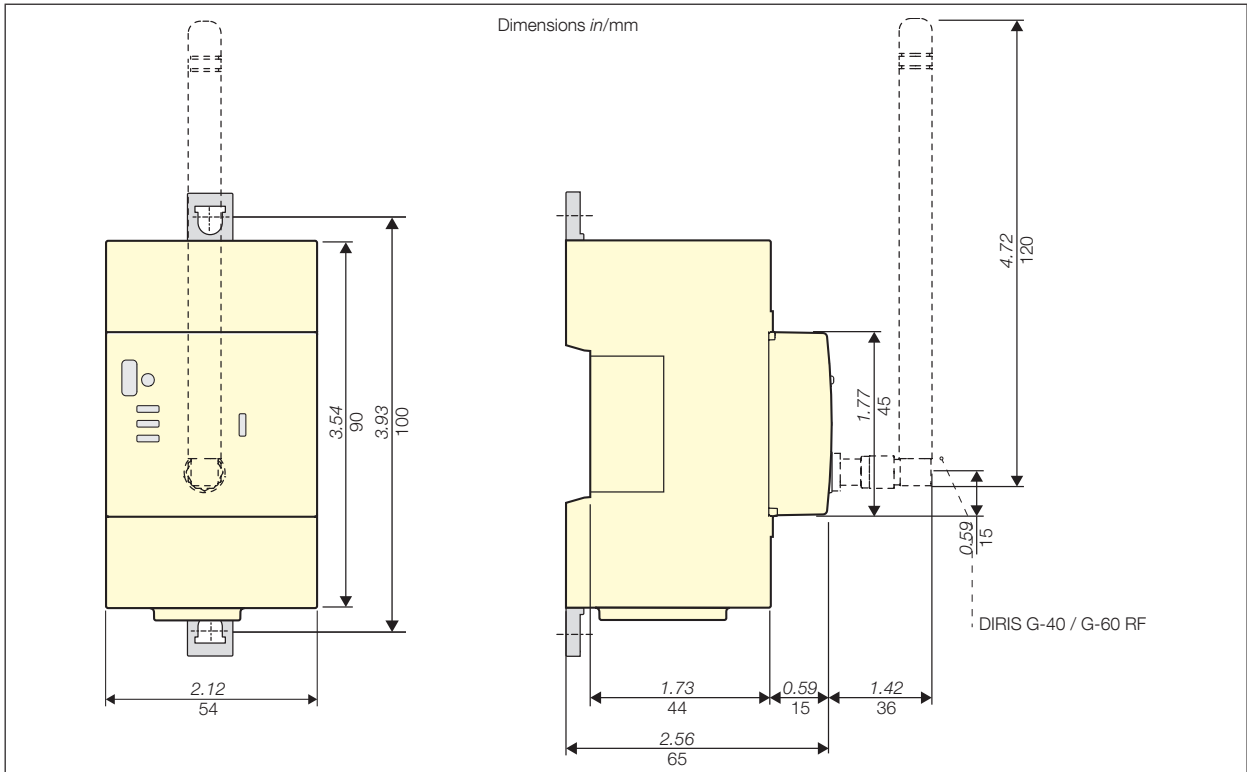

4.1.4. Dimensions





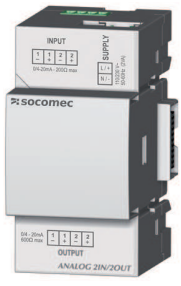

4.2. Presentation of optional modules

The optional modules, which have a modular format, are fitted on the DIRIS B; they are used to extend its functionalities in terms of inputs/outputs and communication modes.

4.2.1. Range

		
DIRIS O-iod	DIRIS O-ioa	DIRIS O-it
Module with 2 digital inputs/outputs	Module with 2 analogue inputs/outputs	Module with 3 temperature inputs
Ref. 4829 0030	Ref. 4829 0031	Ref. 4829 0032

			
DIRIS O-m	DIRIS O-p	DIRIS O-b/ip	DIRIS O-b/mstp
Modbus RS485 communication module	PROFIBUS DPV1 communication module	BACnet/IP communication module	BACnet MS/TP communication module
Ref. 4829 0033	Ref. 4829 0034	Ref. 4829 0035	Ref. 4829 0036

4.2.2. Dimensions

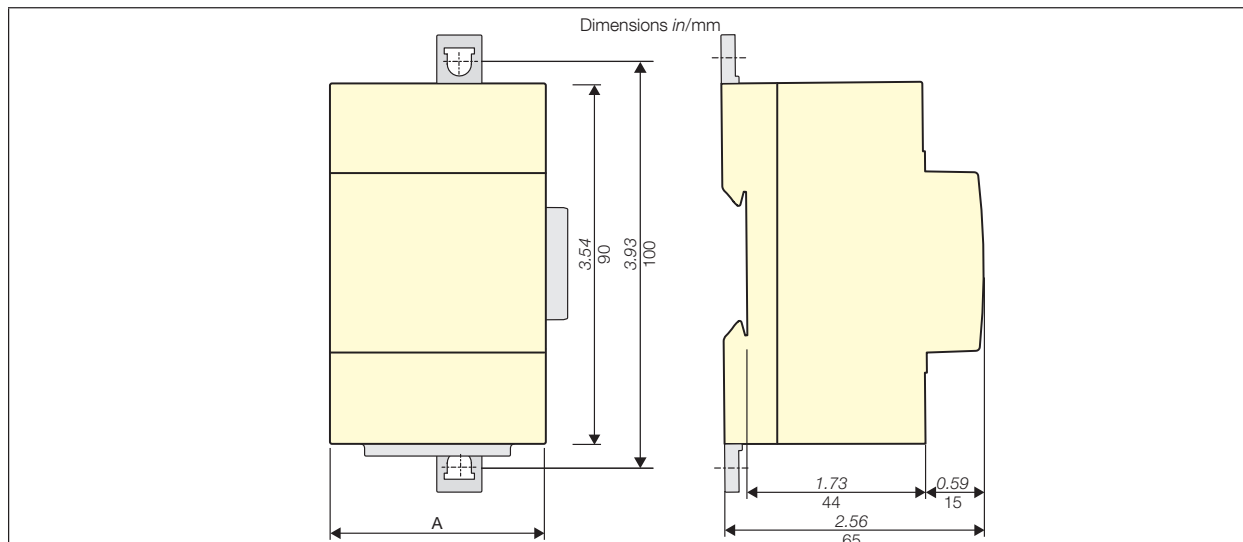

	DIRIS O-iod	DIRIS O-ioa	DIRIS O-it	DIRIS O-m	DIRIS O-p	DIRIS O-b/ip	DIRIS O-b/mstp
A	1.77in / 45mm			2.12in / 54mm			

4.3. Presentation of associated current sensors

Various types of current sensors are connected to the DIRIS B: closed (TE), open (TR) or flexible (TF). The difference between these sensors means they can be adapted to any type of new, existing or temporary installation. They all use a specific link. This type of link provides a quick connection, with no cabling errors. The DIRIS B recognises the sensor size and type. This also guarantees the overall accuracy of the DIRIS B + current sensor measurement chain.

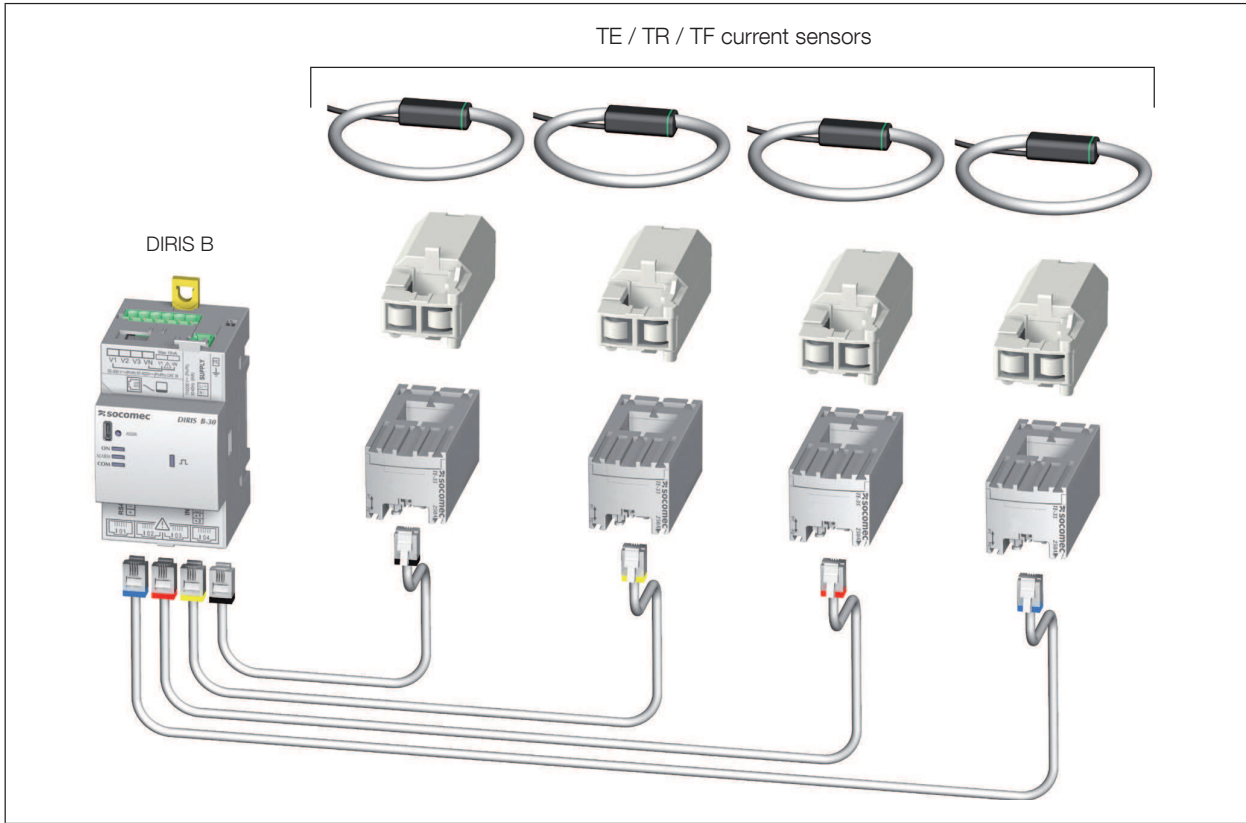

Recommendations:

For connecting the current sensors, use SOCOMEC cables or equivalent only, RJ12 straight cables, twisted pair, unshielded, 300 V cat.III., -20°C / +70°C as per IEC 61010-1 version 3.0.

It is recommended that all the current sensors are installed in the same direction.

Connection cables for current sensors:

RJ12 connection cables	Cable length (m)								
	0.1	0.2	0.3	0.5	1	2	5	10	50 m reel + 100 connectors*
Number of cables	reference	reference	reference	reference	reference	reference	reference	reference	reference
1	-	-	-	-	-	-	4829 0602	4829 0603	4829 0601
3	4829 0580	4829 0581	4829 0582	4829 0595	4829 0583	4829 0584	-	-	-
4				4829 0596	4829 0588	4829 0589	-	-	-
6	4829 0590	4829 0591	4829 0592	4829 0597	4829 0593	4829 0594	-	-	-







* When producing cables, do not exceed a maximum length of 10 metres.

4.3.1. TE solid-core current sensors

The TE solid-core current sensors are used to set up measurement points in a new or existing installation. They are easy to integrate as they are compact and respect the pitch of the circuit breakers. A wide range of accessories are also available for direct fitting on all type of cabling (cable, flexible or rigid busbar) or on a DIN rail support or plate.

Thanks to the specific link, they are recognised by the DIRIS B and the overall accuracy of the measurement chain is guaranteed.

4.3.1.1. Range

						
	TE-18	TE-18	TE-25	TE-35	TE-45	TE-55
Pitch	18 mm	18 mm	25 mm	35 mm	45 mm	55 mm
Nominal current range In	5 - 20 A	25 - 63 A	40 - 160 A	63 - 250 A	160 - 630 A	400 - 1000 A
Actual range	0.1 - 24 A	0.5 - 75 A	0.8 - 192 A	1.26 - 300 A	3.2 - 756 A	8 - 1200 A
Maximum I	24 A	75.6 A	192 A	300 A	756 A	1200 A
Reference	4829 0500	4829 0501	4829 0502	4829 0503	4829 0504	4829 0505

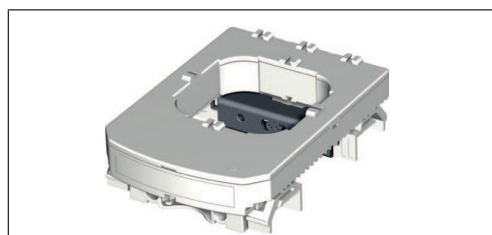

	TE-90
Pitch	90 mm
Nominal current range In	600 - 2000 A
Actual range	12 - 2400 A
Maximum I	2400 A
Reference	4829 0506

4.3.1.2. Dimensions

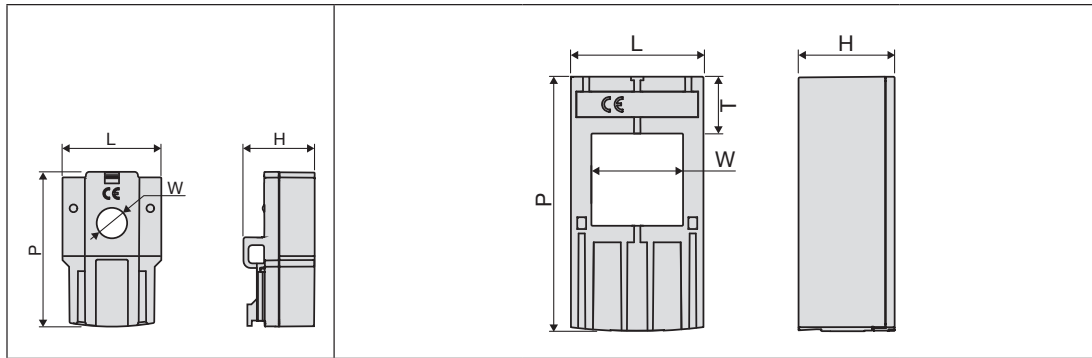

Dimensions in/mm	TE-18	TE-25	TE-35	TE-45	TE-55
Pitch	0.71 18 (staggered assembly)	0.98 25	1.37 35	1.77 45	2.16 55
LxHxD	1.10 x 0.79 x 1.77 28 x 20 x 45	0.98 x 1.28 x 2.56 25 x 32.5 x 65	1.37 x 1.28 x 2.79 35 x 32.5 x 71	1.77 x 1.28 x 3.38 45 x 32.5 x 86	2.16 x 1.28 x 3.93 55 x 32.5 x 100
Aperture (W)	∅ 0.33 ∅ 8.4	0.53 x 0.53 13.5 x 13.5	0.82 x 0.82 21 x 21	1.22 x 1.22 31 x 31	1.61 x 1.61 41 x 41
(T)	-	0.69 17.5	0.69 17.5	0.77 19.5	0.85 21.5

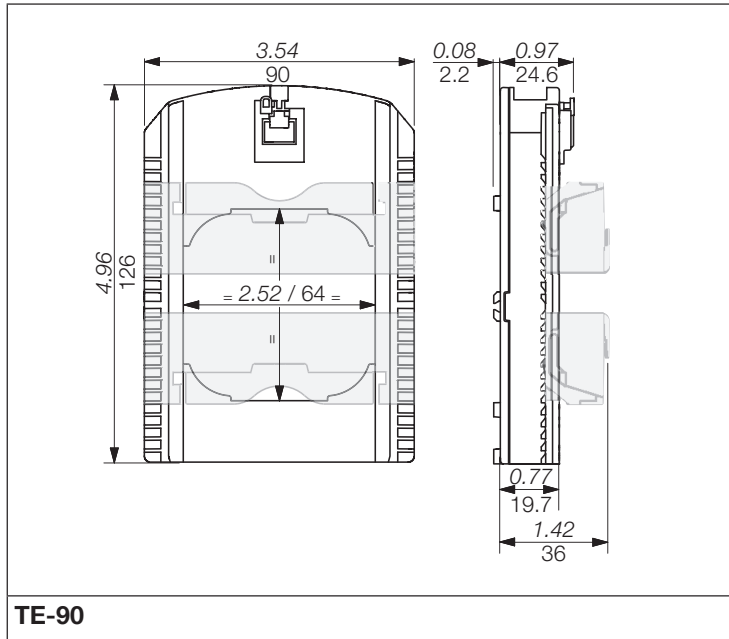

Dimensions in/mm

TE-90

4.3.2. TR split-core current sensors

The TR split-core current sensors are used to set up measurement points in a new or existing installation without interfering with its cabling. Thanks to the specific link, they are recognised by the DIRIS B and the overall accuracy of the measurement chain is guaranteed.

4.3.2.1. Range

Four models are available from 25A to 600A to analyse several types of loads.

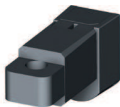
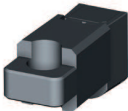
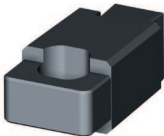
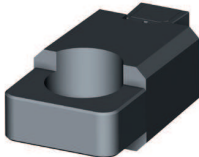
				
	TR-10	TR-16	TR-24	TR-36
Cable passage diameter	10mm	16mm	24mm	36mm
Nominal current range I_n	25 - 75 A	32 - 100 A	63 - 200 A	200 - 600 A
Actual range	0.5 - 90 A	0.64 - 120 A	1.26 - 200 A	4 - 720 A
Maximum I	90A	120A	240A	720A
Reference	4829 0551	4829 0552	4829 0553	4829 0554

4.3.2.2. Dimensions

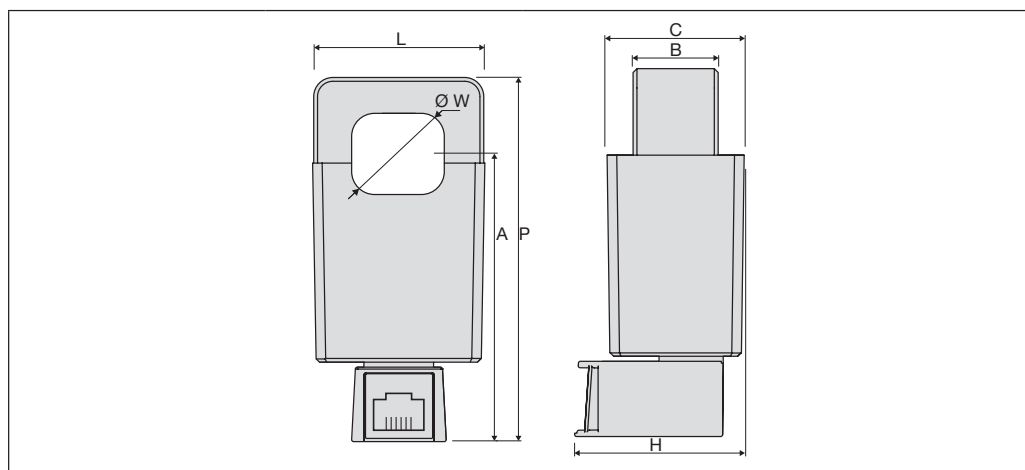

Dimensions in/mm	TR-10	TR-16	TR-24	TR-36
LxHxD	0.98 x 1.54 x 2.79 25 x 39 x 71	1.18 x 1.65 x 2.91 30 x 42 x 74	1.77 x 1.73 x 3.74 45 x 44 x 95	2.24 x 1.65 x 4.37 57 x 42 x 111
W	0.39 10	0.63 16	0.94 24	1.42 36
A	2.28 58	2.40 61	2.83 72	3.23 82
B	0.57 14.5	0.75 19	0.87 22	0.87 22
C	1.02 26	1.22 31	1.34 34	1.59 40.5

4.3.3. TF flexible current sensors

The TF flexible current sensors use the Rogowski principle which enables a large current range to be covered without saturation. Flexible design and easy-opening system for quick installation in electrical enclosures. They are particularly suitable for adding measuring points in existing installations and for test campaigns.

4.3.3.1. Range

Three models are available, covering a large current range up to 6000 A with openings of different shapes and sizes.

An integrator will be required to shape the current signal. With its specific link you can connect it directly to the DIRIS B, which can identify it.

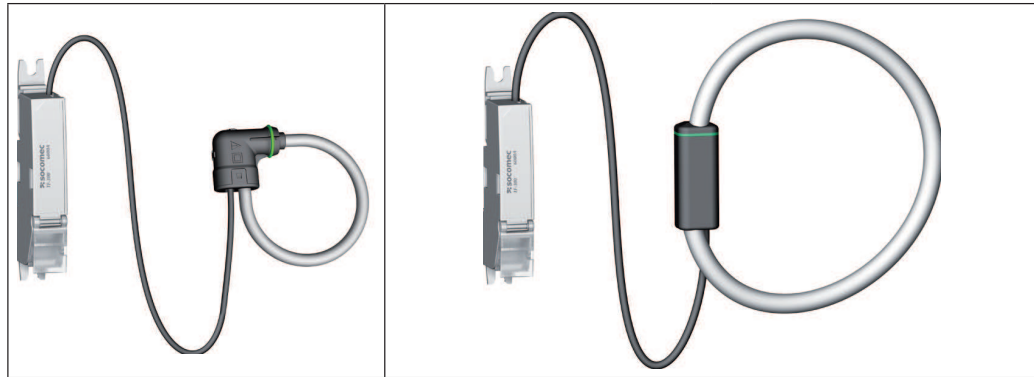

	TF-55	TF-120	TF-300
Loop length	55 mm	120 mm	300 mm
Nominal current range In	150 - 600 A	500 - 2000 A	1600 - 6000 A
Actual range	3 - 720 A	10 - 2400 A	32 - 7200 A
Reference	4829 0570	4829 0571	4829 0572

4.3.3.2. Dimensions

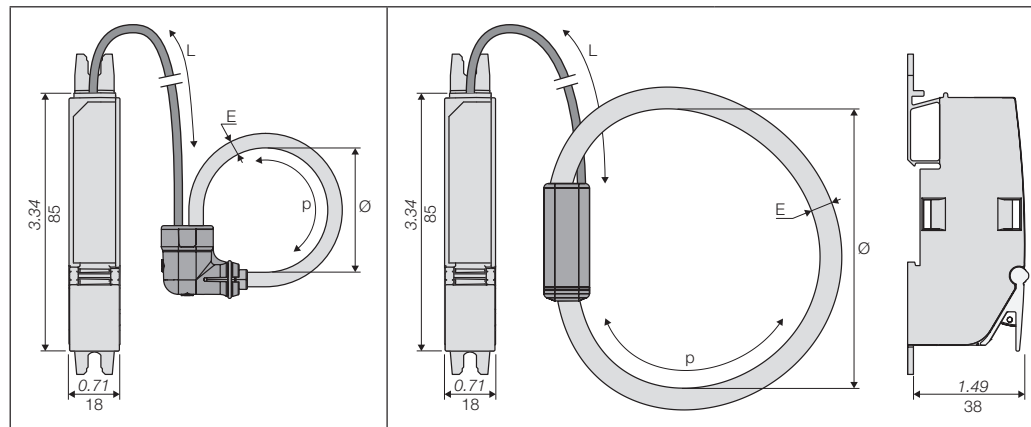

Dimensions in/mm	TF-55	TF-120	TF-300
Diameter	2.16 55	4.72 120	11.81 300
p	7.16 182	14.80 376	37.08 942
T	0.23 6	0.43 11	0.43 11
L		59.05 1500	

4.3.4. Adapters for 5A sensors

The adapter lets you use a standard sensor supplying a 1A or 5A current to the secondary sensor. When this kind of sensor is used, the overall accuracy of the DIRIS B + sensor is not guaranteed and will depend on the accuracy of the associated sensor (see standard "norm IEC 61557-12 annex D" for more information). The primary current is max. 10000A / 5A or 2000A / 1A.

4.3.4.1. Range

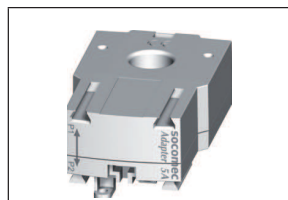

5A adapter

I nom.	5A
I max.	6A
Reference	4829 0599

4.3.4.2. Dimensions

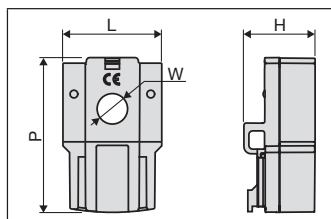

Dimensions in/mm

5A adapter

LxHxD	1.10 x 0.79 x 1.77 28 x 20 x 45
Aperture (W)	∅ 0.33 ∅ 8.4

5. MOUNTING

The following paragraphs describe the installation of the DIRIS B, the optional modules and the associated sensors.

5.1. Recommendations and safety

Refer to the safety instructions (section “2. Hazards and warnings”, page 5)

5.2. Installing the DIRIS B

5.2.1. DIN rail mounting

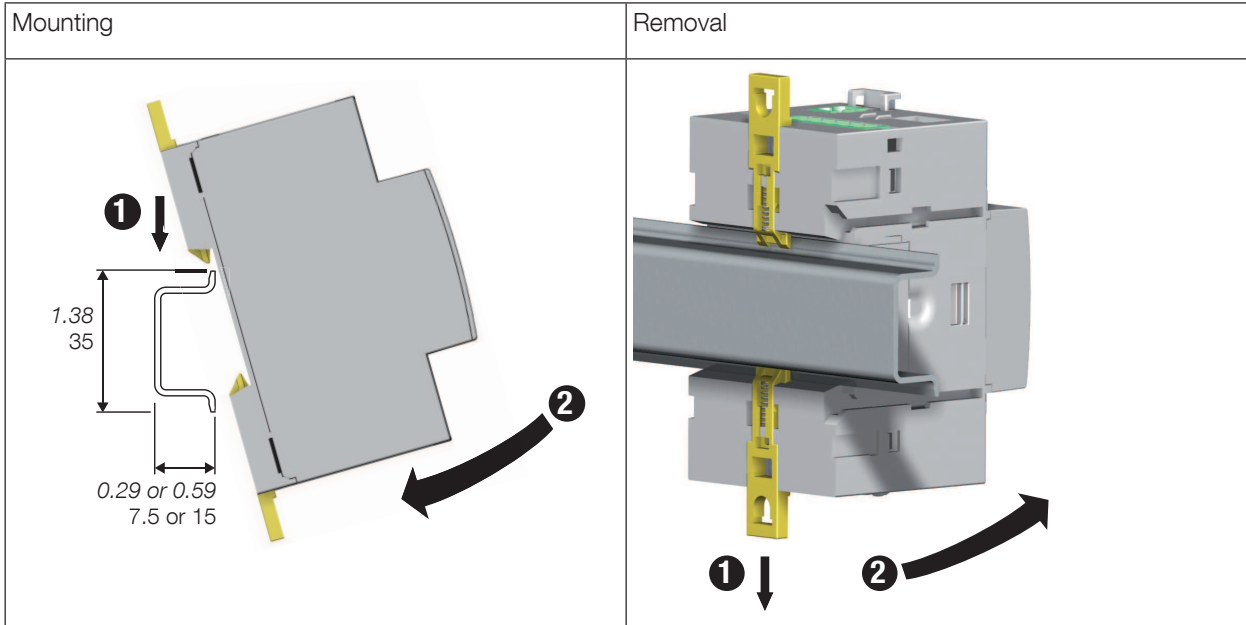

5.2.2. Plate mounting

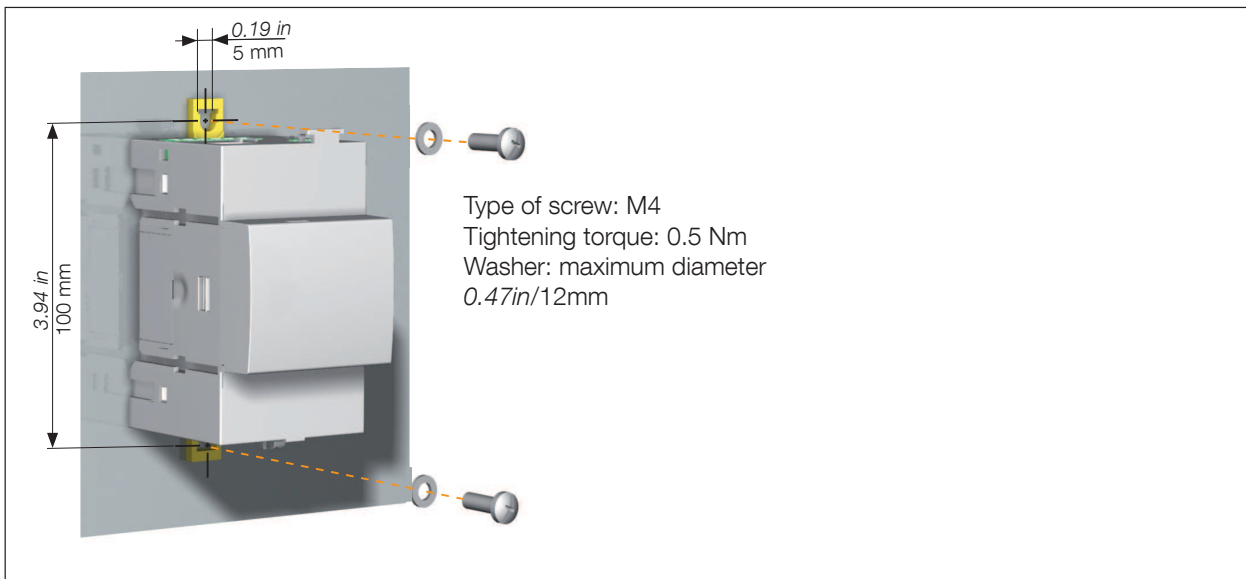

5.2.3. Sealing accessory for sensors

Reference	Sealing case for terminal
4829 0600	x20

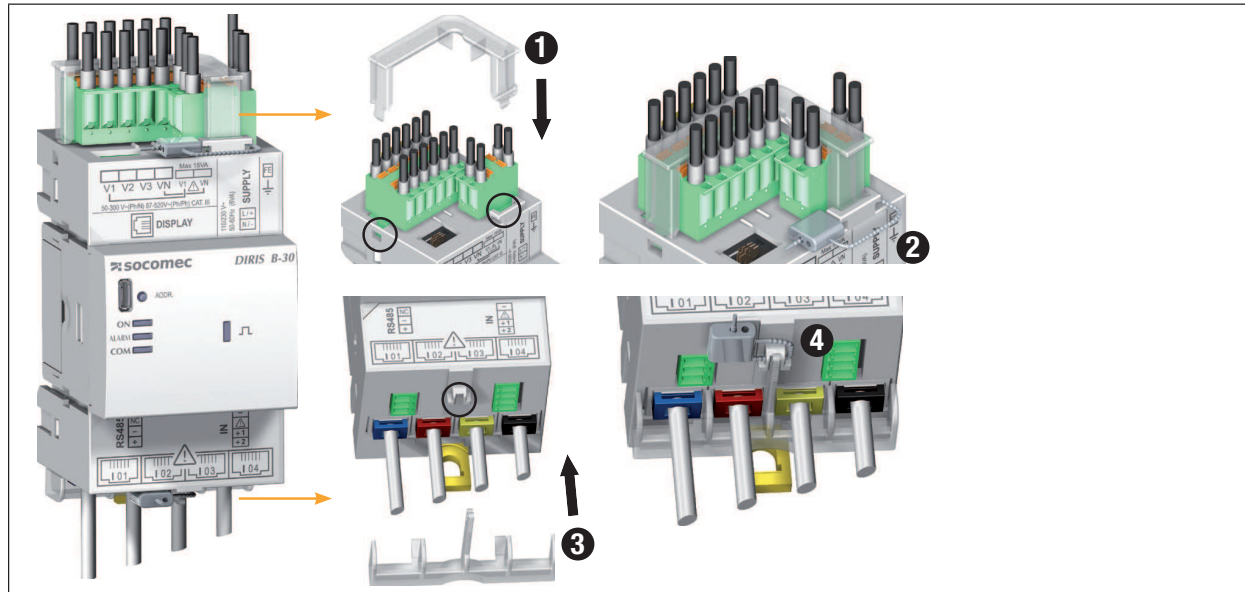

5.3. Installing the optional modules

5.3.1. Installing an optional module on DIRIS B

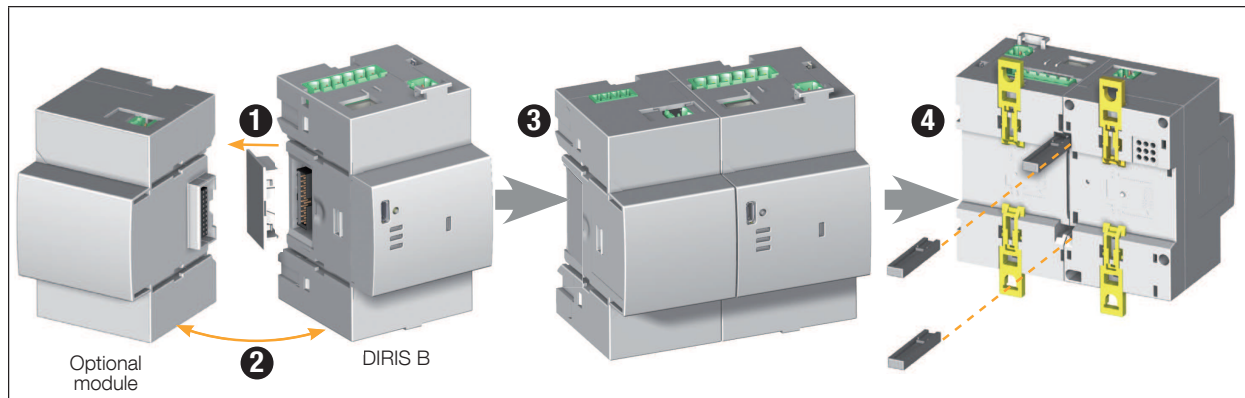

5.3.2. Installing an optional module on an optional module

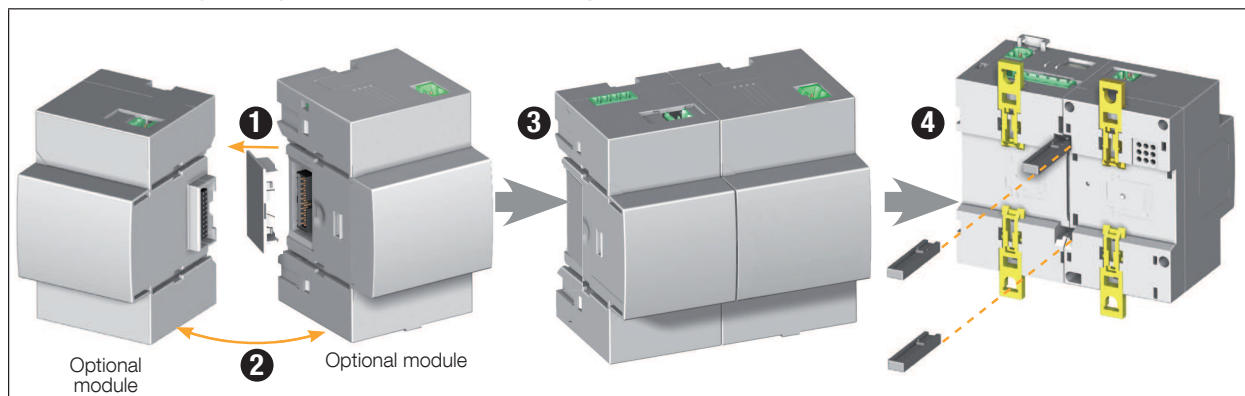

The following guidelines for installation must be observed:

- A maximum of 4 optional modules can be installed on the DIRIS B
- One single temperature module (DIRIS O-it) may be used.
- One single RS485 communication module (DIRIS O-m) may be used and must always be positioned last during installation
- The DIRIS B assembly with its optional modules must be installed on a DIN rail or base plate.

5.4. Installing TE solid-core sensors

5.4.1. Mounting accessories

The list of mounting accessories supplied with the sensors are listed below:

Reference		Pitch	DIN rail and plate mounting	DIN rail mounting	Plate mounting	Busbar mounting
4829 0500 4829 0501	TE-18	18 mm	x 1			
4829 0502	TE-25	25 mm		x2	x4	
4829 0503	TE-35	35 mm		x2	x4	x2
4829 0504	TE-45	45 mm		x2	x4	x2
4829 0505	TE-55	55 mm		x2	x4	x2
4829 0506	TE-90	90 mm	x2		x6	

5.4.2. DIN rail mounting

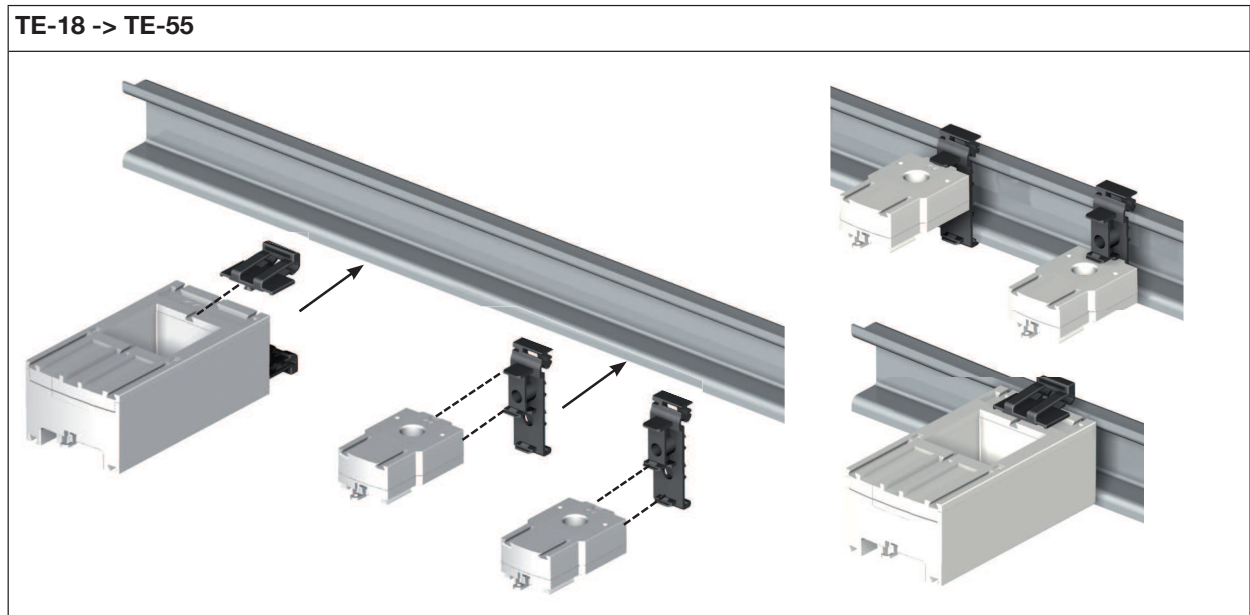

TE-90

Removing clamps

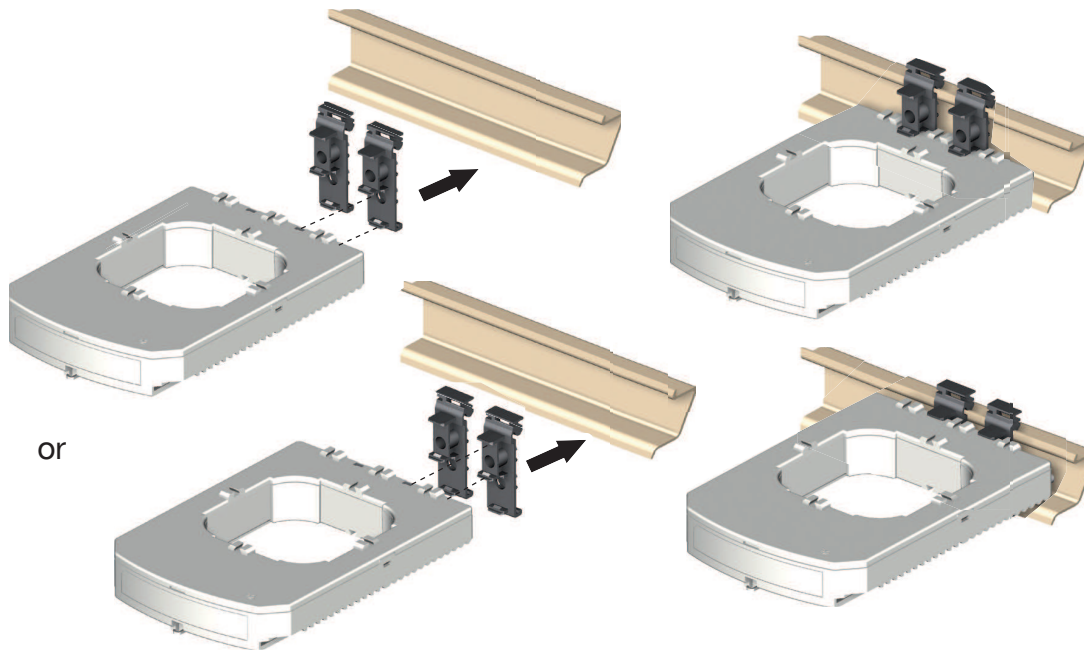
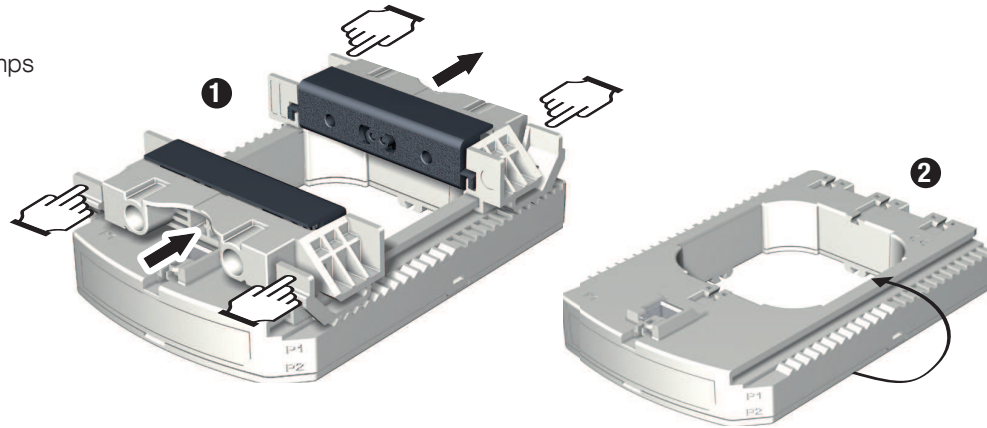

NB: Install sensor TE-90 to the DIN rail to make it easier to install. This is a temporary installation. Use the clamps to install the TE-90 sensors on the DIN rail.

5.4.3. Plate mounting

TE-18

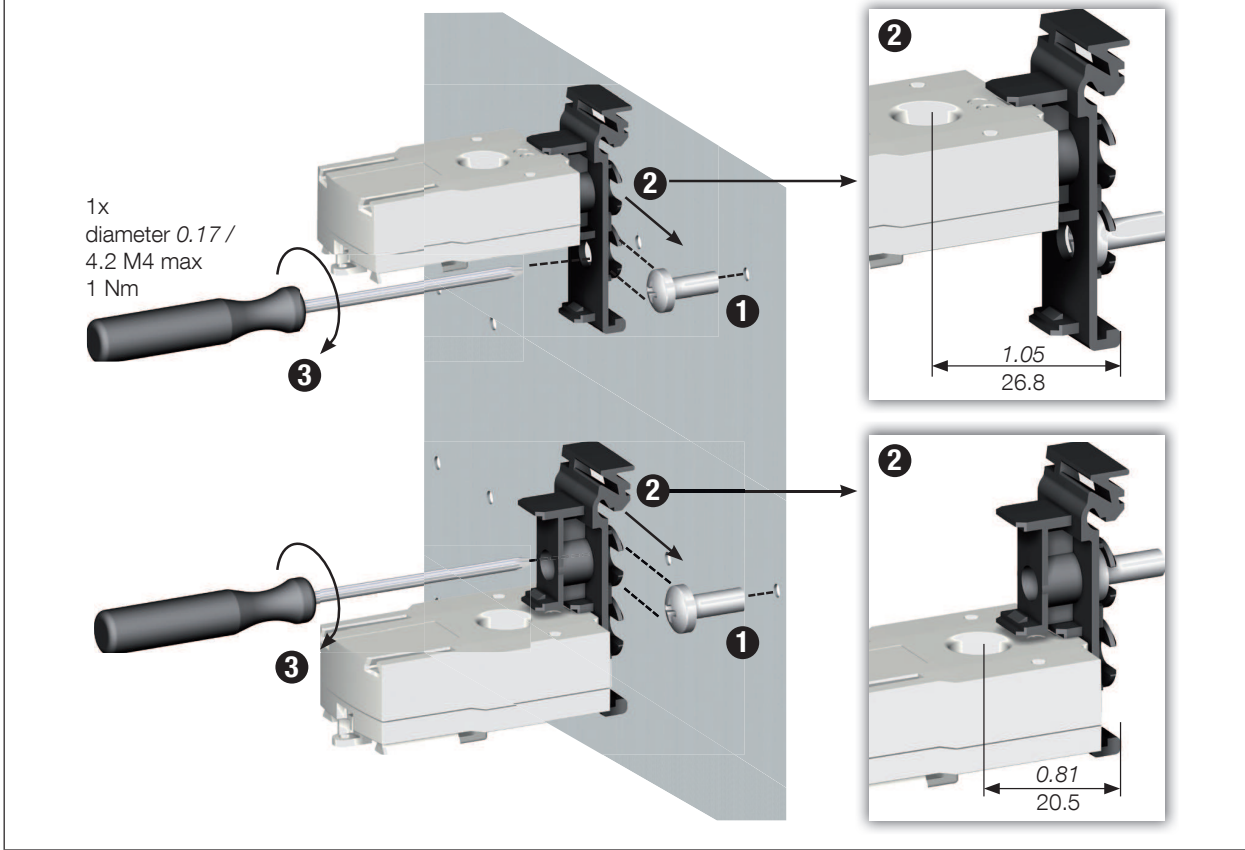

TE-25 -> TE-55

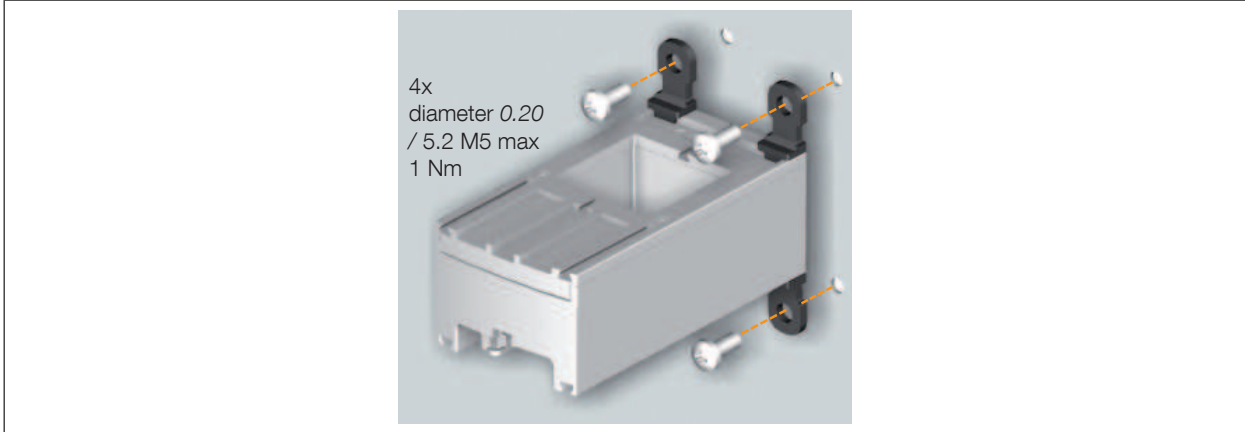

TE-90

Removing clamps

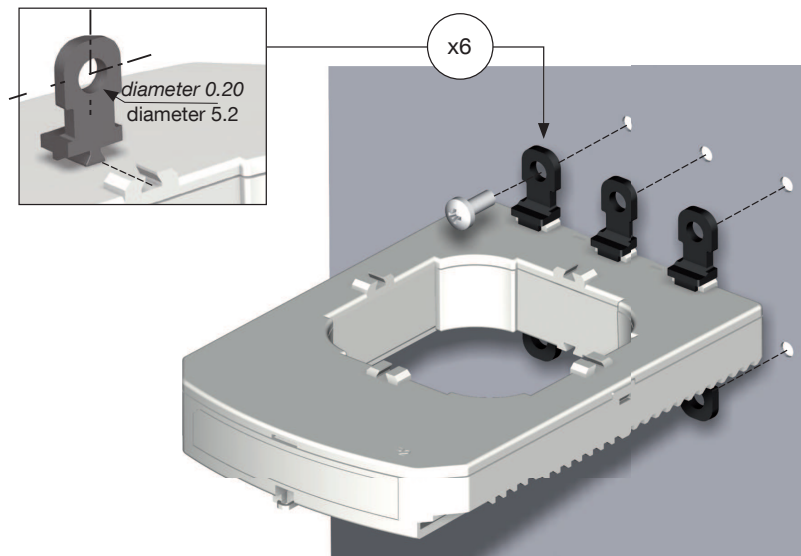
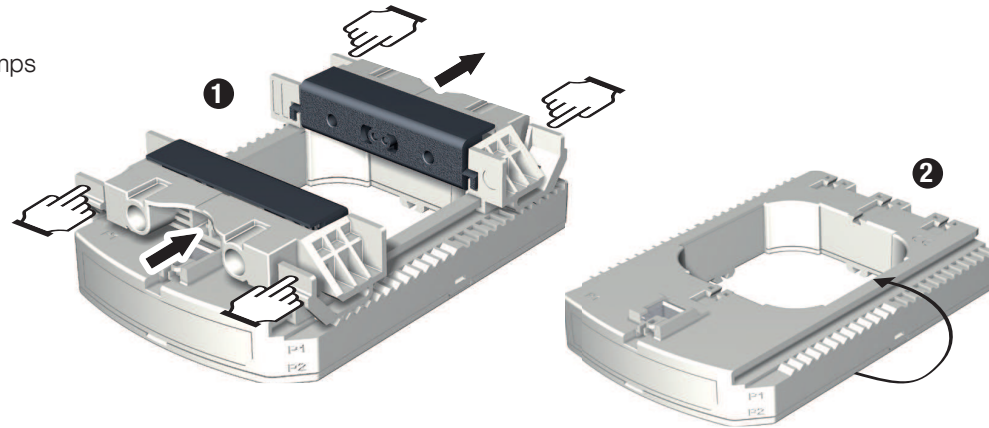

NB: Use the clamps to install the TE-90 sensors on the board.

5.4.4. Installing on a cable with clamping collar

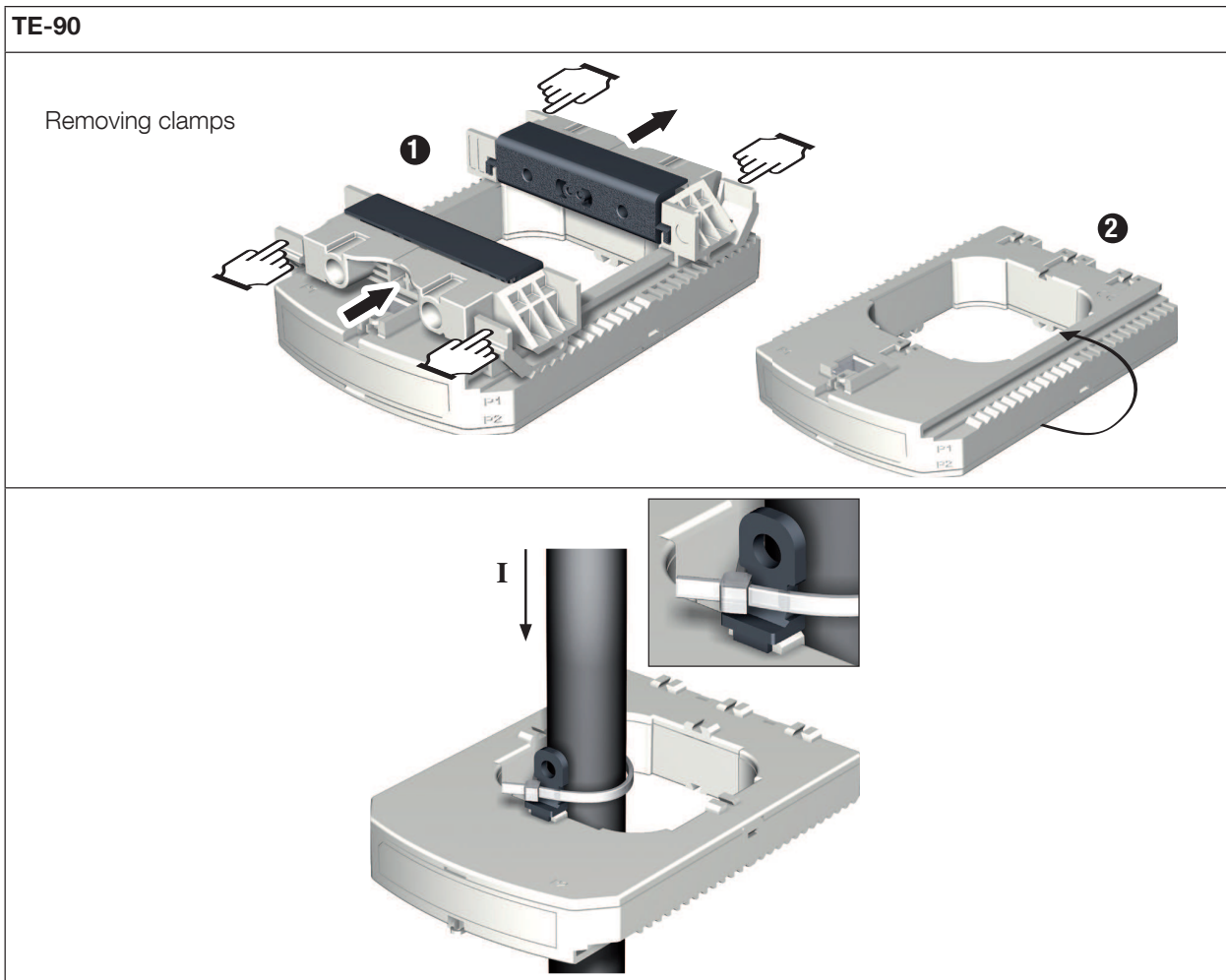
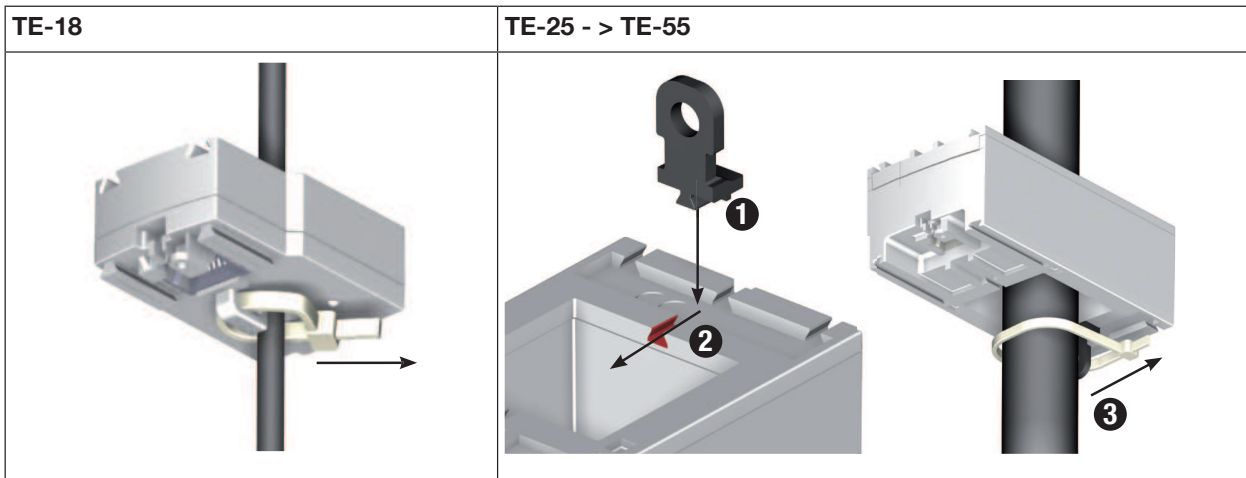

NB: Use the clamps to install the TE-90 sensors on a cable with clamping collar.



Do NOT clamp or pull out NON-INSULATED conductors carrying DANGEROUS VOLTAGE which could cause an electric shock, burn or arc flash.
Ref. IEC 61010-2-032

5.4.5. Bar mounting

TE-35 -> TE-55

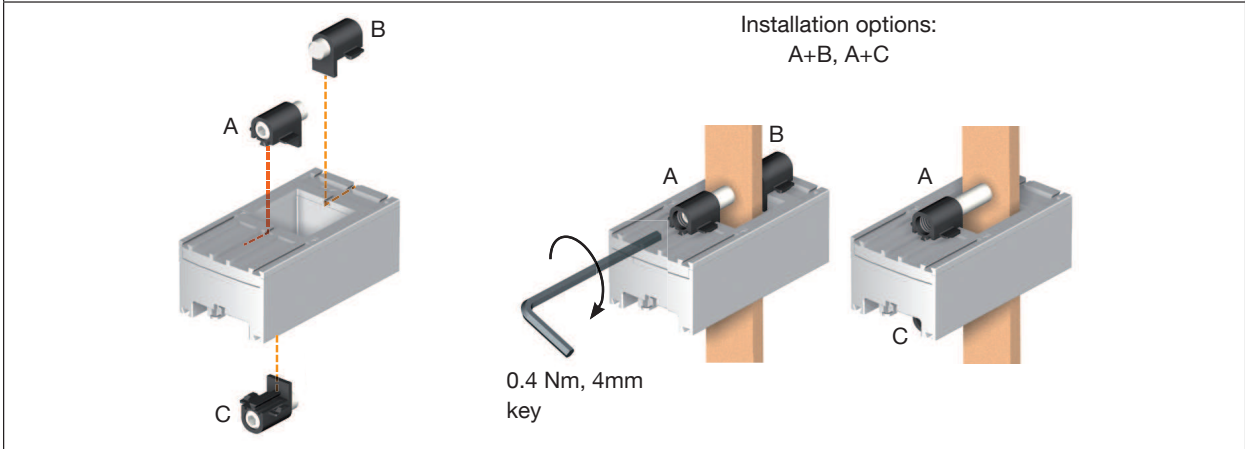

TE-90

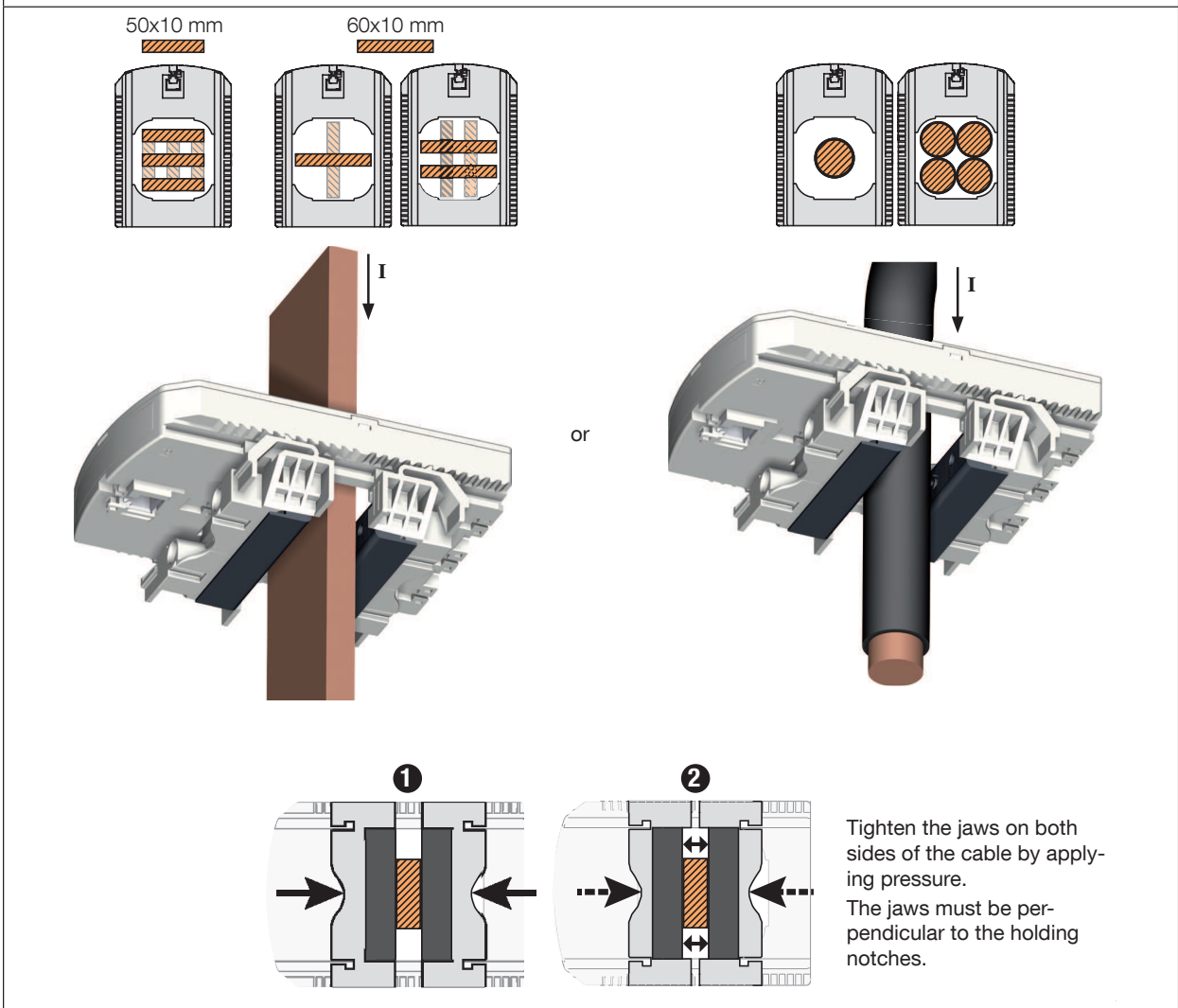

Do NOT clamp or pull out NON-INSULATED conductors carrying DANGEROUS VOLTAGE which could cause an electric shock, burn or arc flash.
Ref. IEC 61010-2-032

5.4.6. Sensors assembly

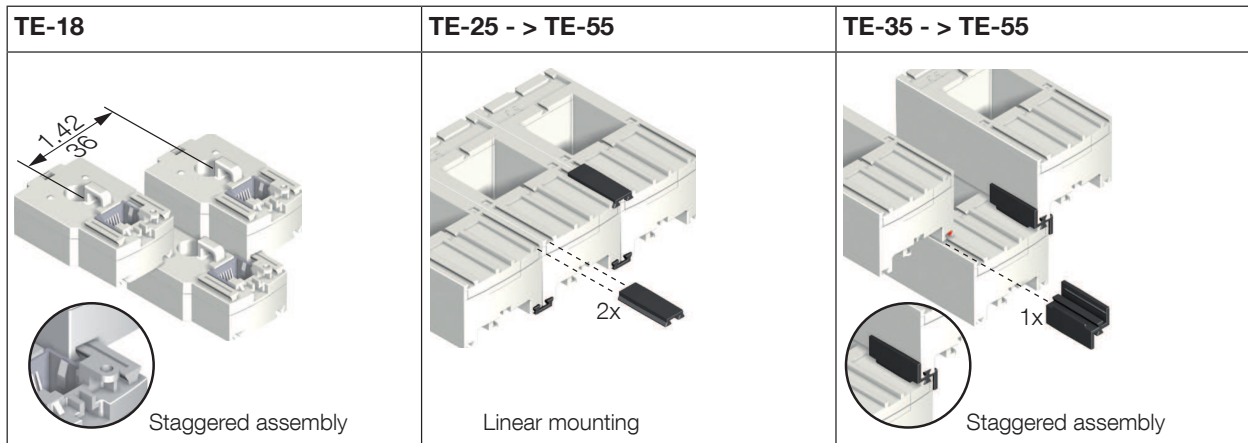

Mounting accessories for sensor combination:

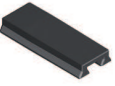
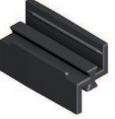
		
Reference	Linear assembly	Staggered assembly
4829 0598	x30	

These accessories must be ordered separately.

5.4.7. Sealing accessories for sensors

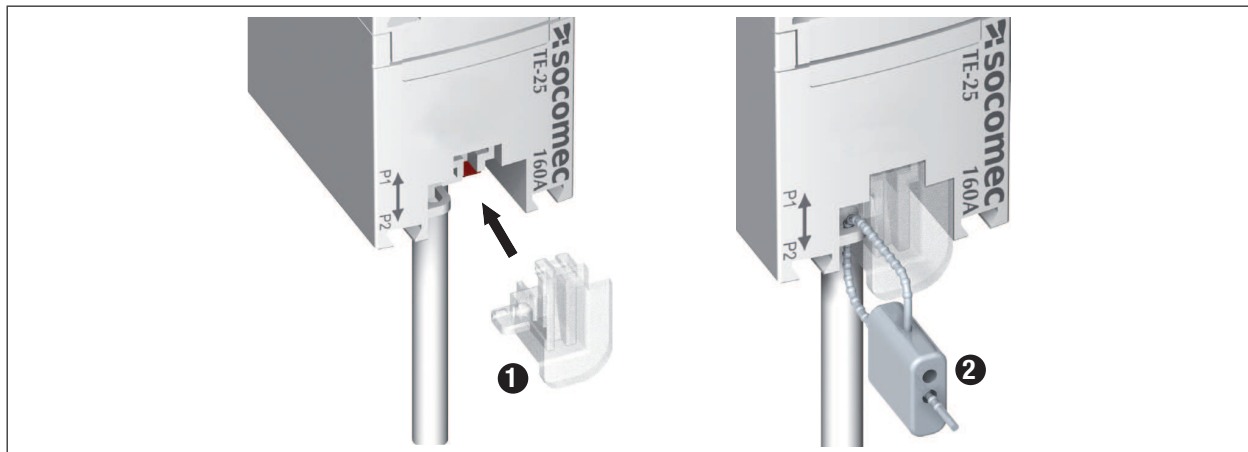

Reference	Sealing case for terminal
4829 0600	x20

These accessories must be ordered separately.

5.5. Installing TR split-core sensors

5.5.1. Cable mounting

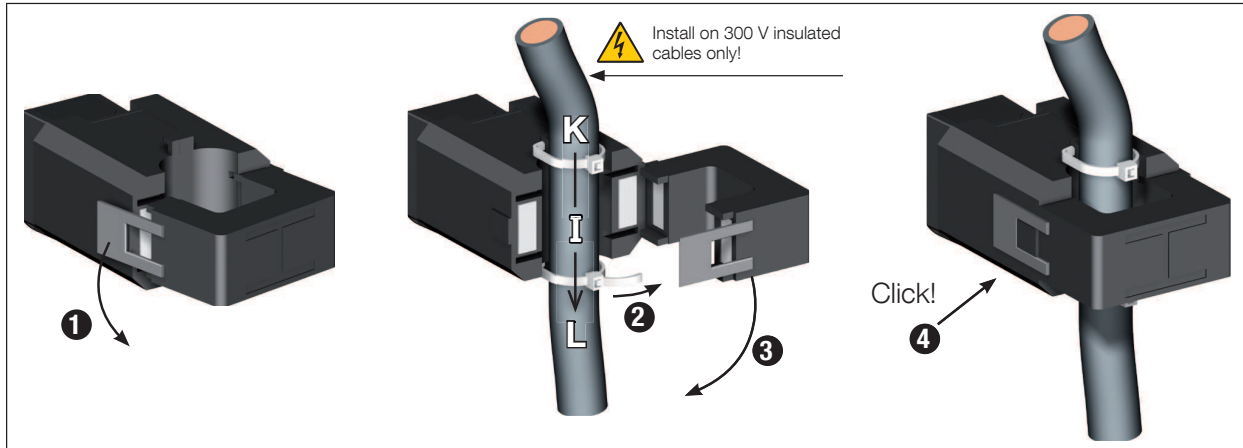

Do NOT clamp or pull out NON-INSULATED conductors carrying DANGEROUS VOLTAGE which could cause an electric shock, burn or arc flash.
Ref. IEC 61010-2-032



Before closing the TR sensor, check that the air gap is clean (no contamination or corrosion)

5.6. stranded sensors TE mounting

5.6.1. Installing the casing

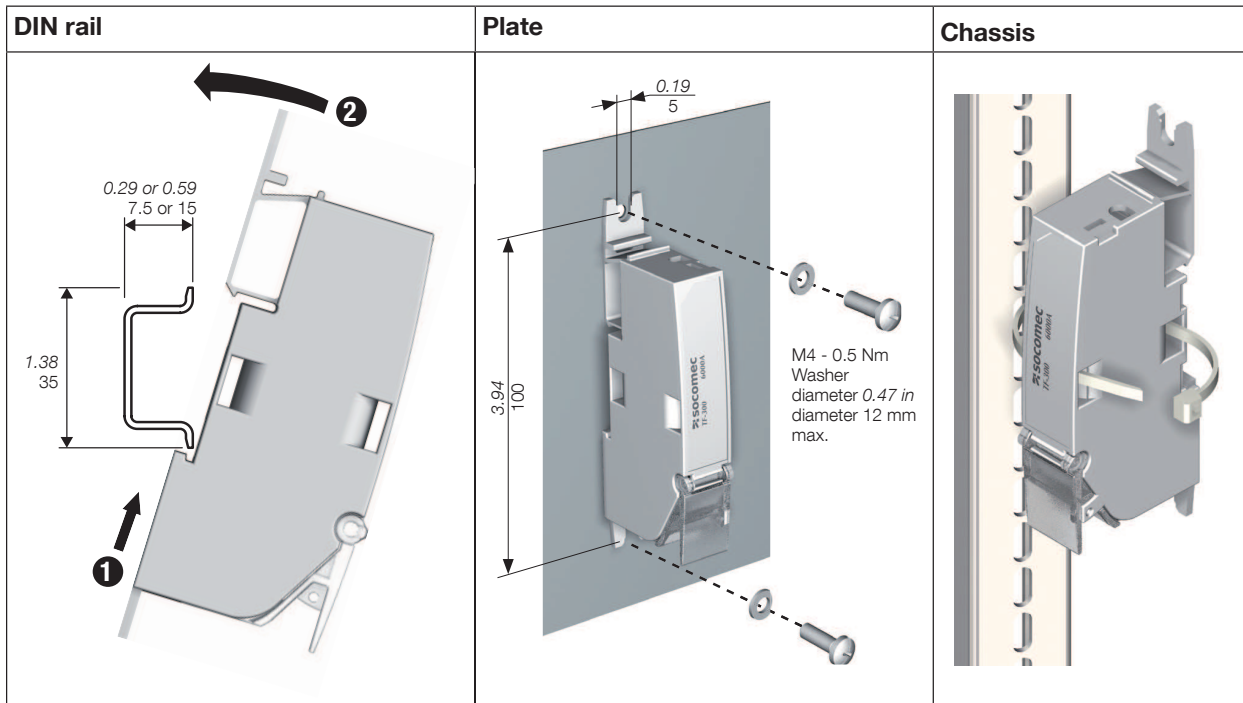

5.6.2. Cable mounting

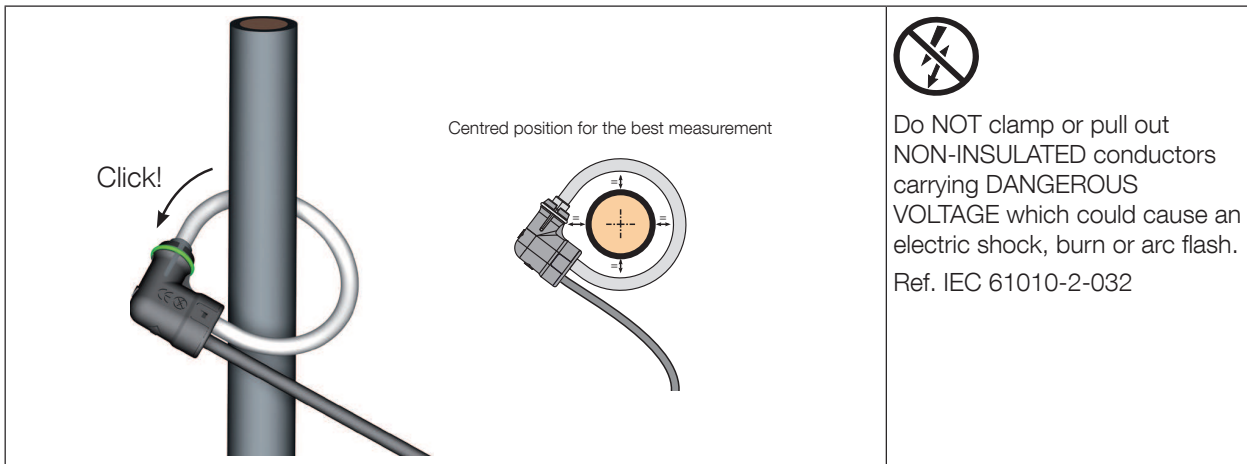

5.6.3. Bar mounting

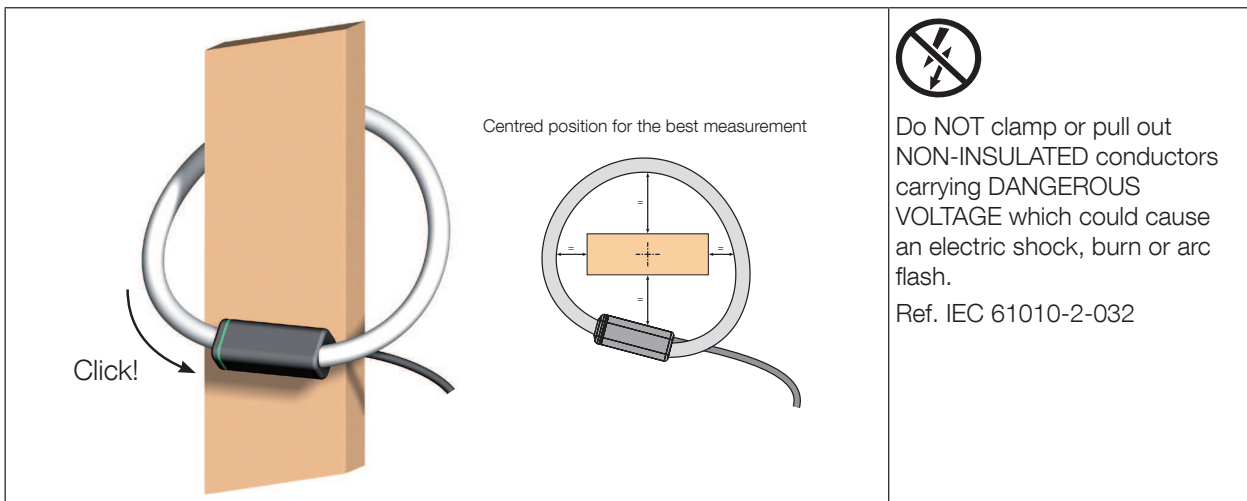

5.7. Installing the 5A adapter

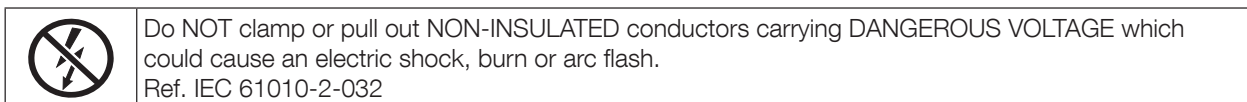
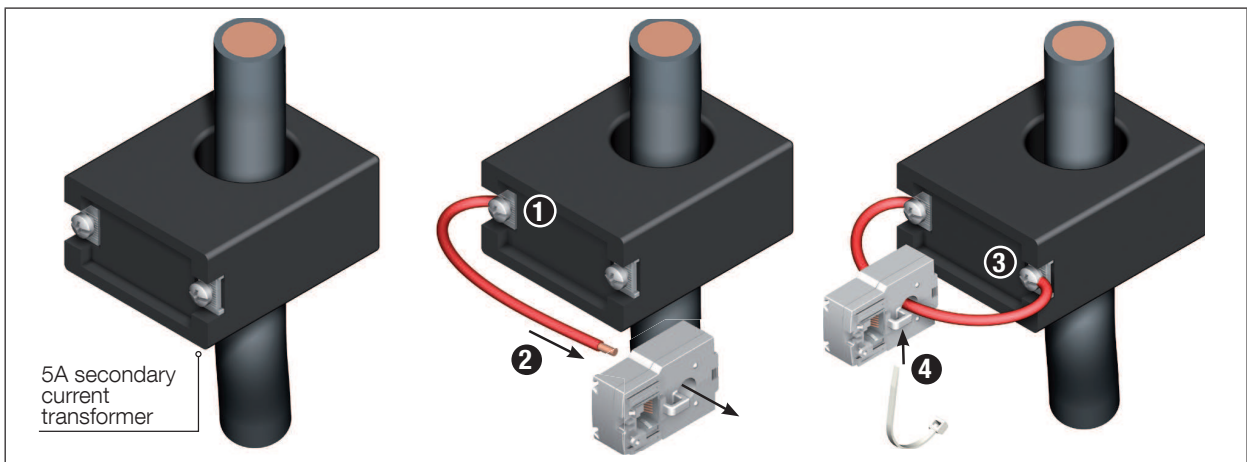

6. CONNECTION

6.1. Connecting the DIRIS B

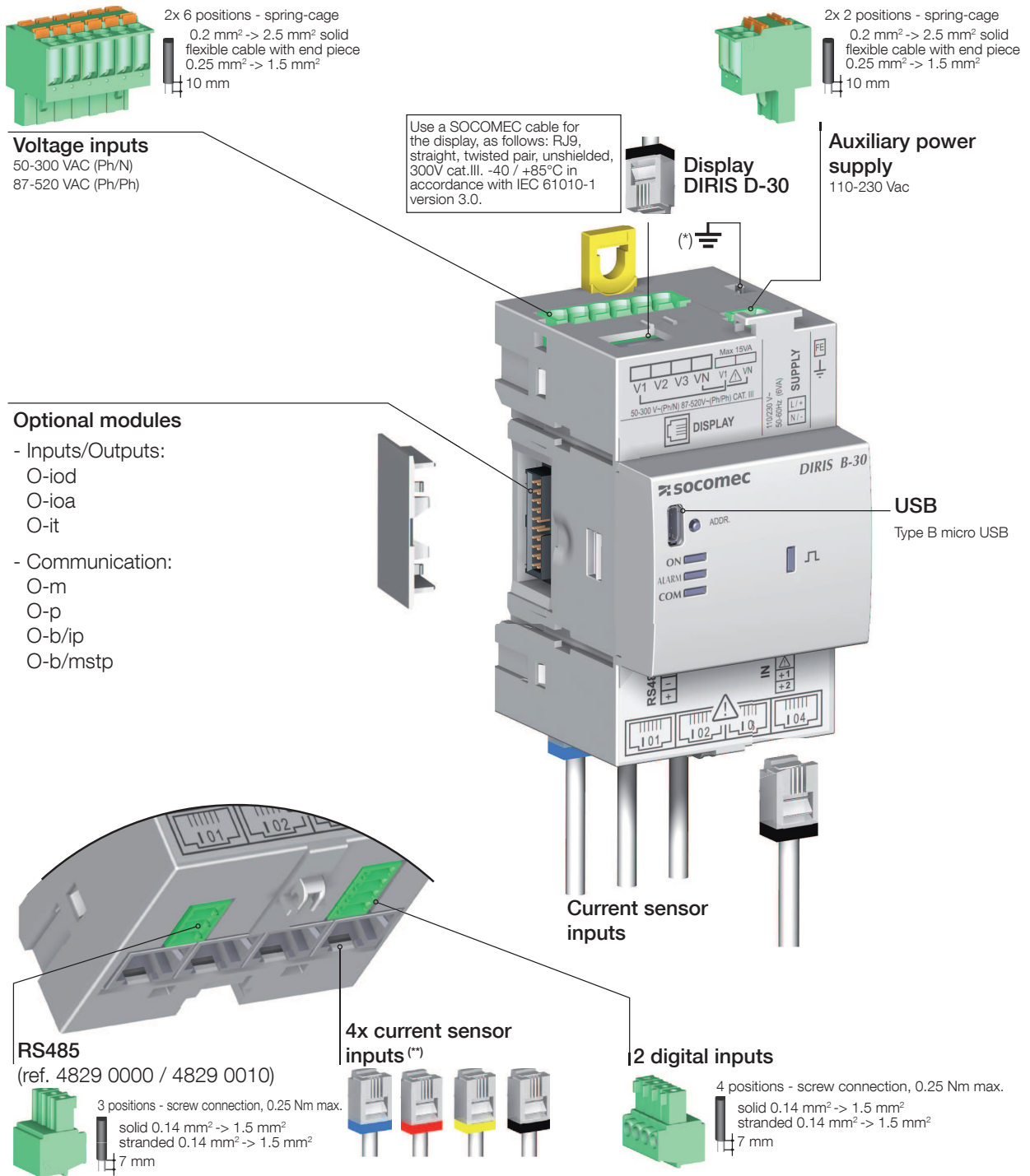

(*) Earth must not be used in a neutral IT system
(**) Always connect input I01 first.

Current measurement

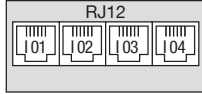

Always connect input I01 first.

Voltage and auxiliary power supply measurement

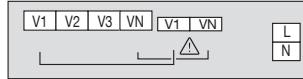

Self-powered

Easy connection of the power supply from the measurement terminal (specific terminals)

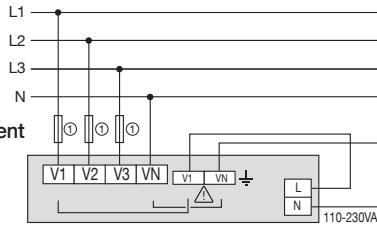

1. 0.5 A gG / 0.5 A class CC fuses.

Separated power supply

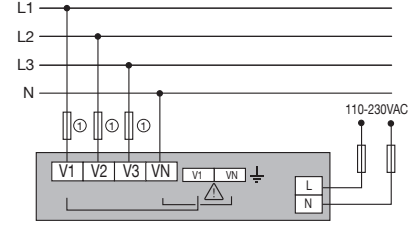

1. 0.5 A gG / 0.5 A class CC fuses.

2 inputs supplied by the product

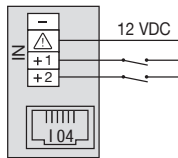

2 inputs with external power supply

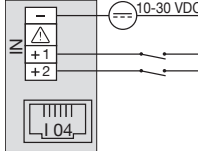

RS485

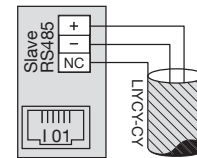

RJ9 for DIRIS D-30 (Self-powered and data)



Power supply of optional modules

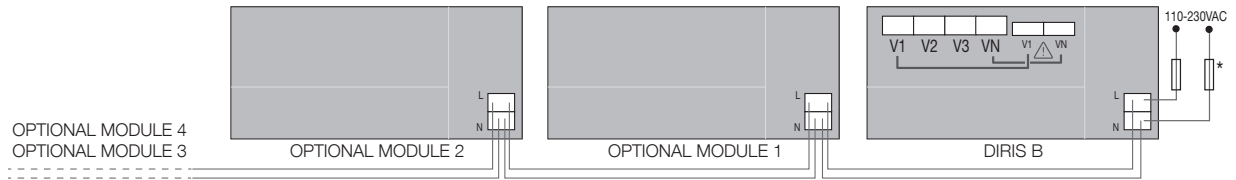

*0.5 A gG / BS 88 2A gG / 0.5 A class CC fuse

6.2. Connecting the optional modules

6.2.1. Input/output modules

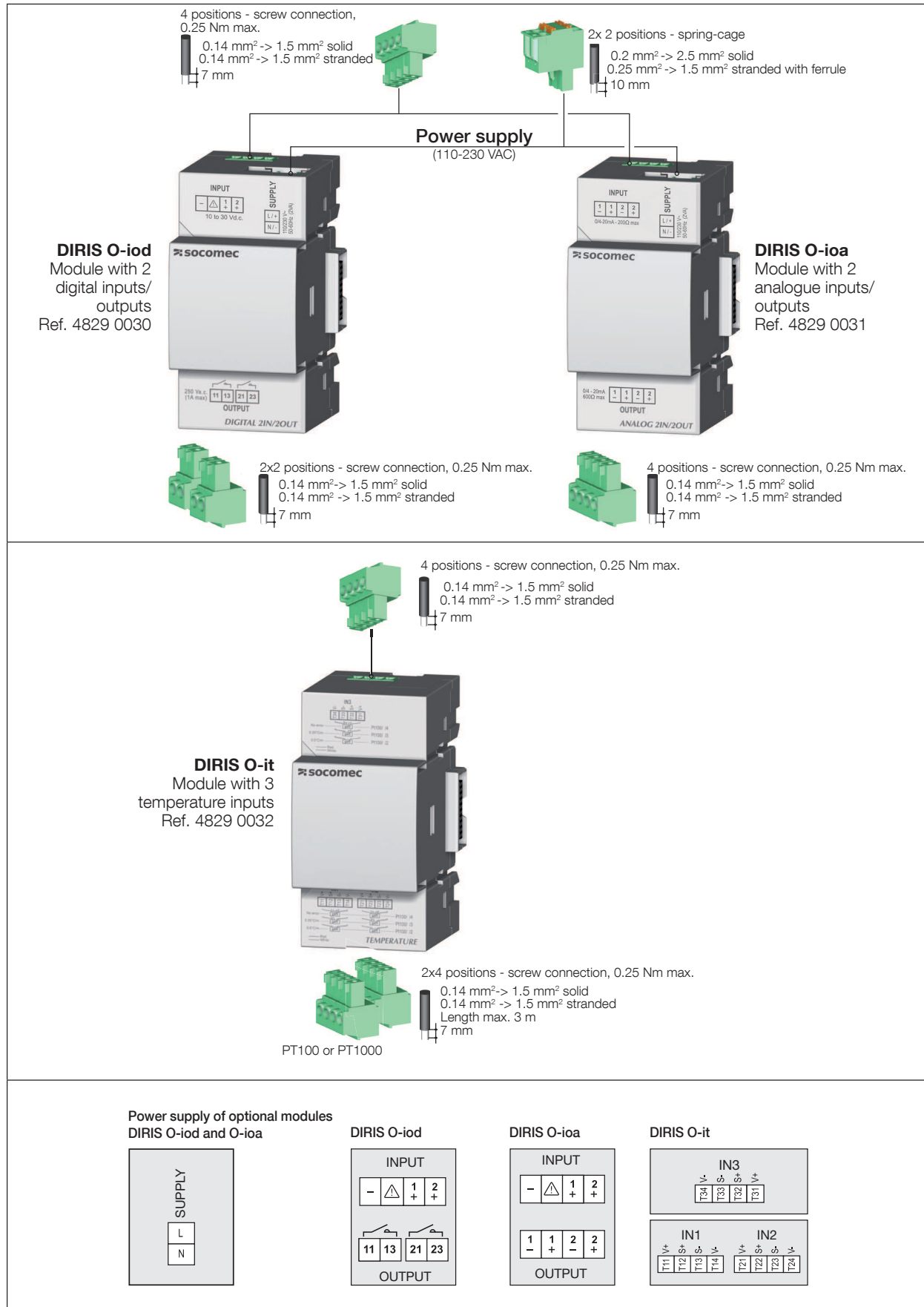

6.2.2. Communication modules

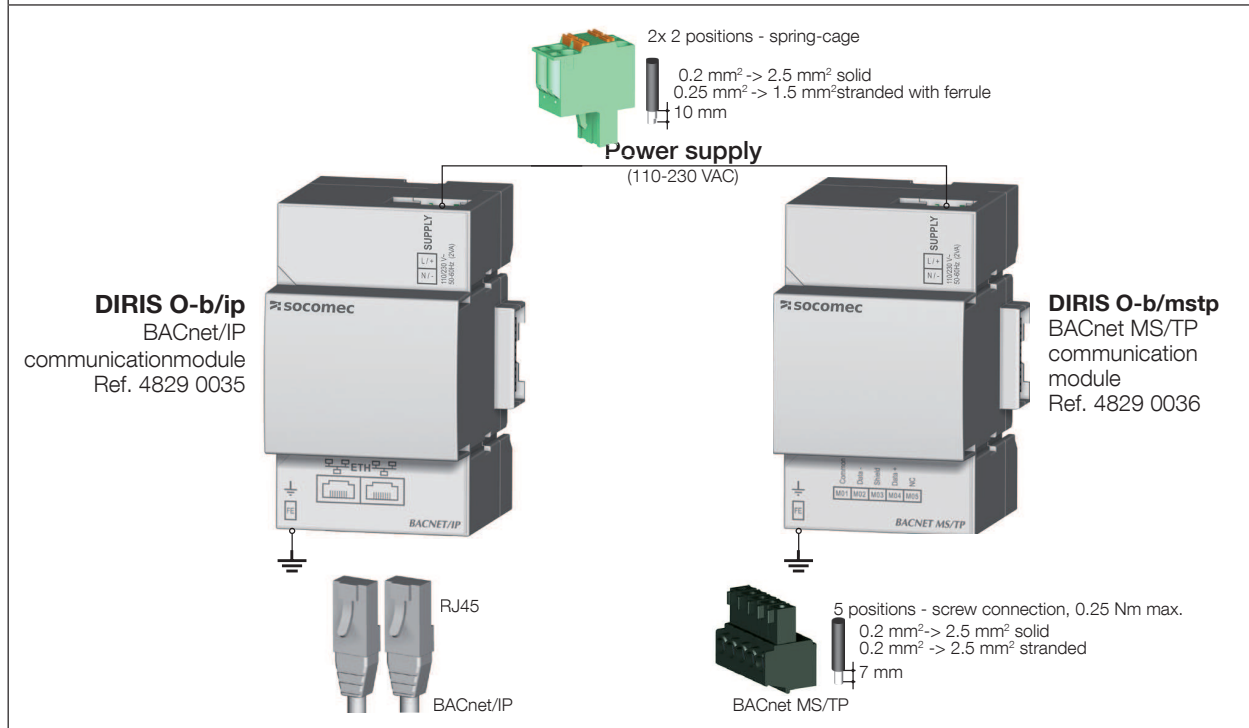
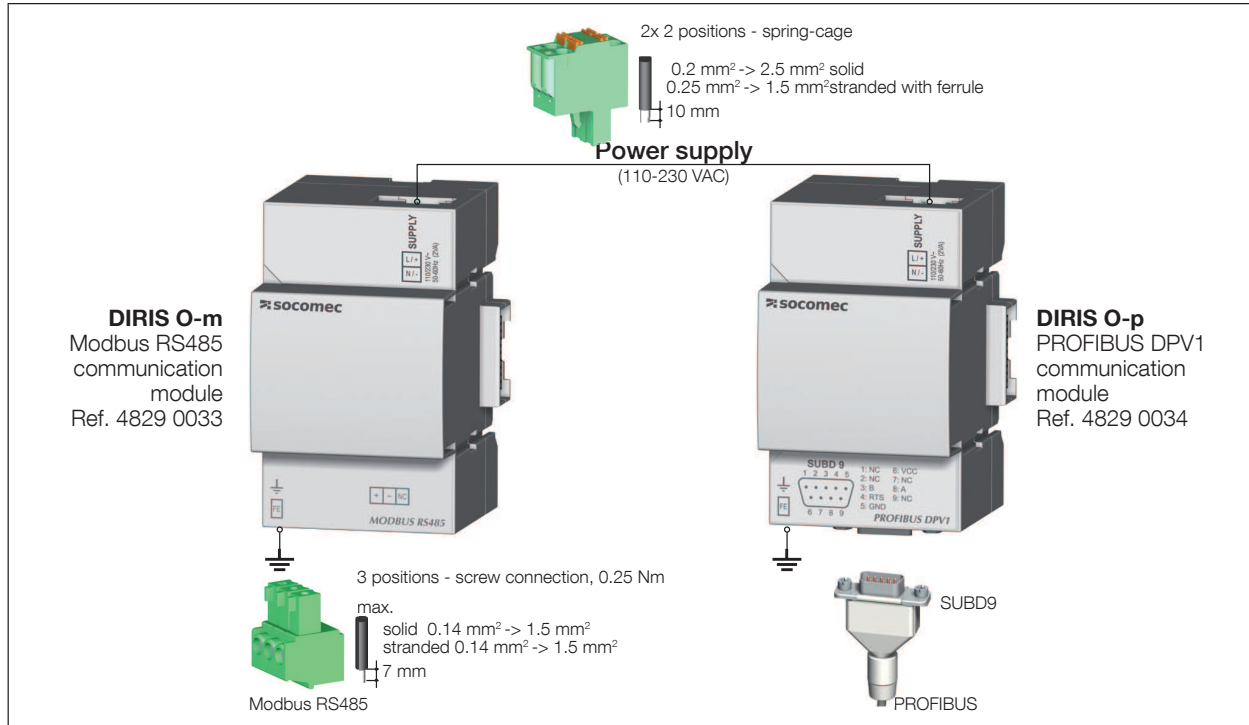

DIRIS O-m RS485

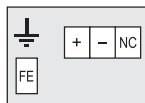

DIRIS O-p

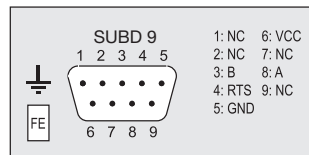

DIRIS O-b/ip

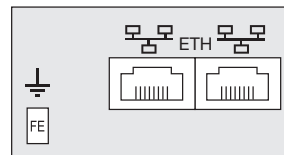

DIRIS O-b/mstp

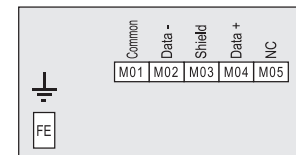

6.3. Connecting the current sensors

6.3.1. Connection concept

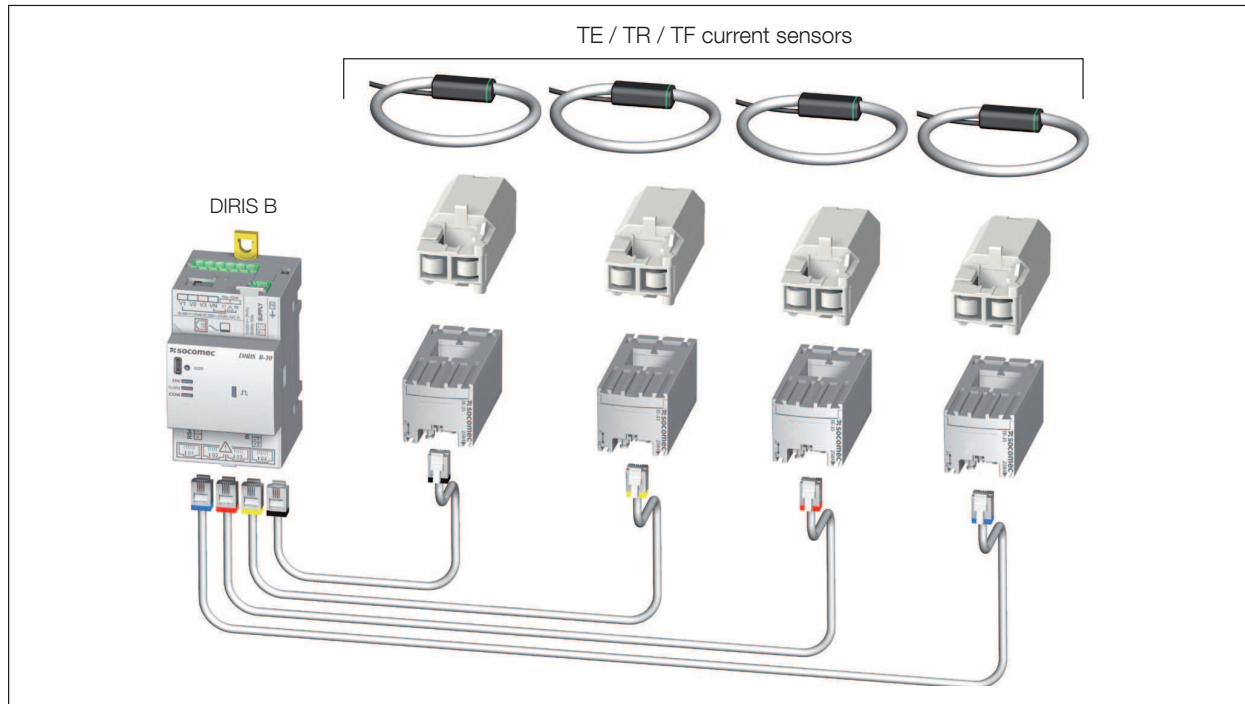

Recommendations:

- Use only SOCOMEC cables for the current sensors or equivalent cables of the following type: RJ12, straight, twisted pair, unshielded, 300V cat.III. -40 / +85°C in accordance with IEC 61010-1 Ed. 3.0.
- It is recommended that current sensors are installed in the same direction.

6.3.2. Details of the RJ12 connections for each current sensor

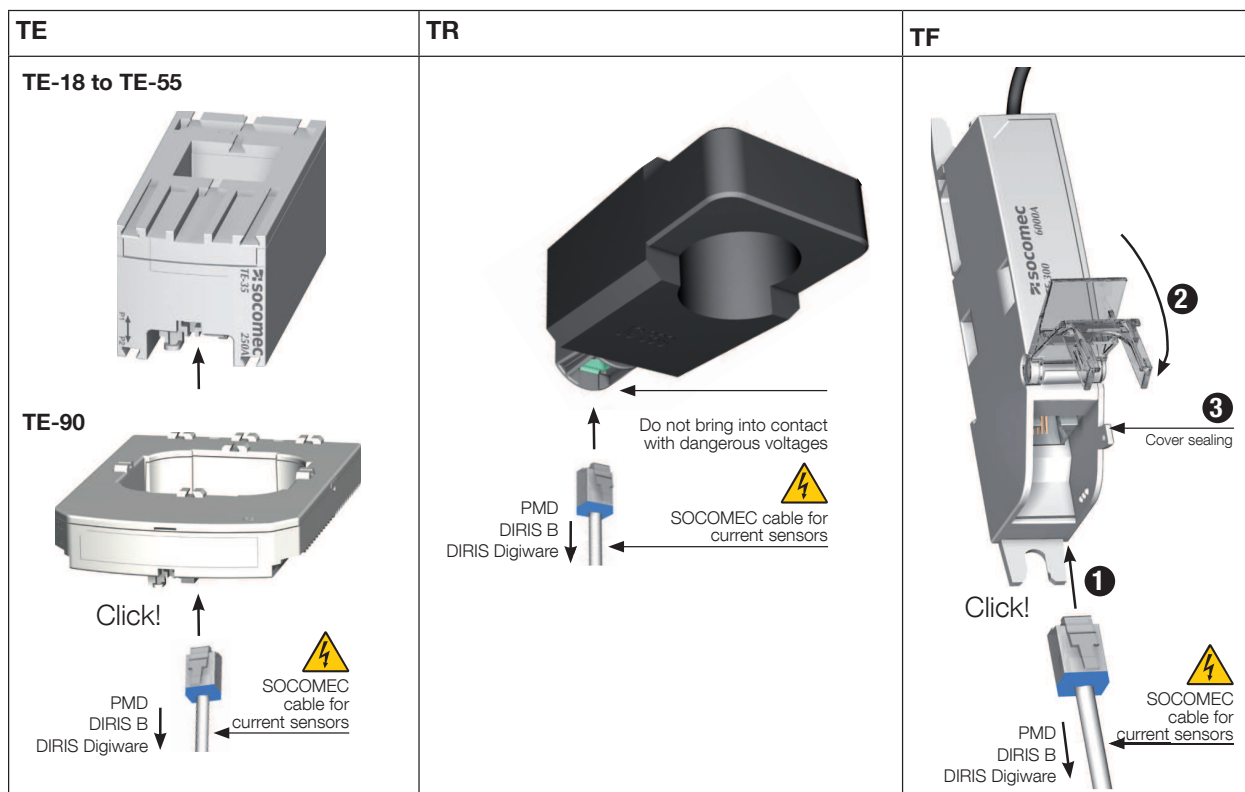

6.3.3. Connecting to the electrical network and loads

The DIRIS B can be used on either single-phase, two-phase or three-phase networks.

Different loads will then be measured simultaneously, allowing great flexibility in terms of where it is fitted in the installation. The loads are measured using several types of sensor (closed, split-core, flexible) selected depending on the application. The link between the DIRIS B and its associated sensors is performed using cables with RJ12 connectors. These connectors enable rapid, trouble-free installation, in complete safety, with no risk of the connector being inverted, and also offers automatic detection of the connected sensors.

In addition, the DIRIS B is able to identify the majority of load types to be measured: single-phase, three-phase with or without neutral using 1, 2, 3 or 4 sensors for balanced or unbalanced loads. Several loads can be measured simultaneously.

The overall accuracy of the DIRIS B + sensors measurement chain is guaranteed. To guarantee this accuracy, SOCOMEC cables must be used for the current sensors.

6.3.3.1. Configurable loads based on the network type

The table below summarises the loads that it is possible to configure depending on the type of network at the installation.

Network type	Configurable load
1P+N	1P+N – 1CT
2P	2P – 1CT
2P+N	2P+N – 2CT / 2P – 1CT / 1P+N – 1CT
3P*	3P – 3CT / 3P – 2CT / 3P – 1CT
3P+N	3P+N – 4CT / 3P+N – 3CT / 3P+N – 1CT / 3P – 3CT / 3P – 2CT / 3P – 1CT / 1P+N – 1CT

(*) Note: Single-phase loads cannot exist on a 3P network.

6.3.3.2. Description of the main network and load combinations

Legend:

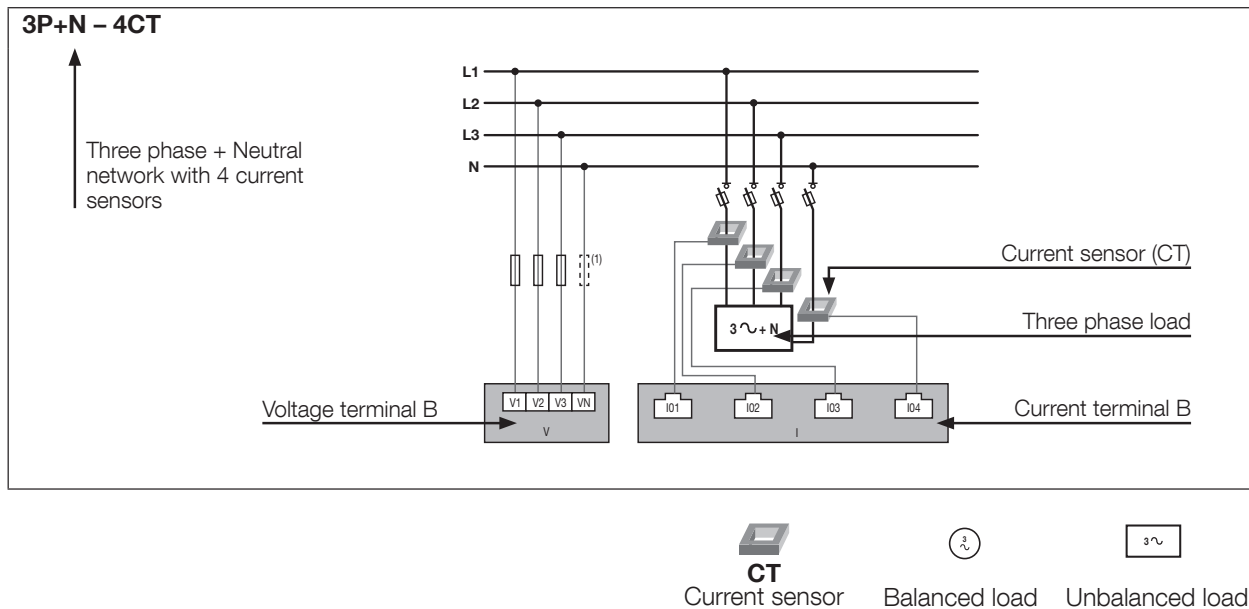

Each current input is individual; see below for some connection examples:

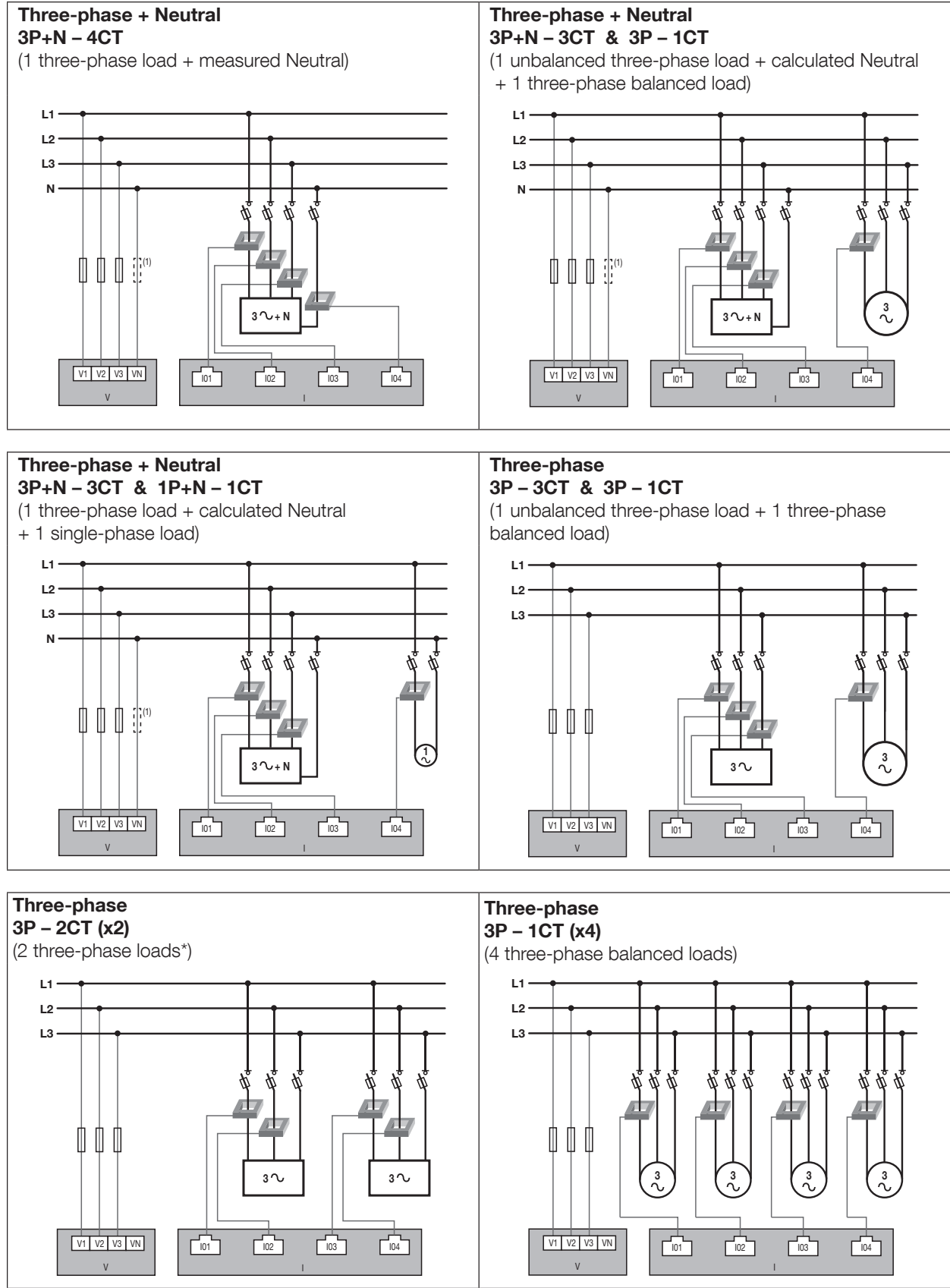

 Fuse: 0.5 A gG / BS 88 2A gG / 0.5 A class CC

**Two-phase + Neutral
2P+N – 2CT (x2)**

(2 two-phase loads)

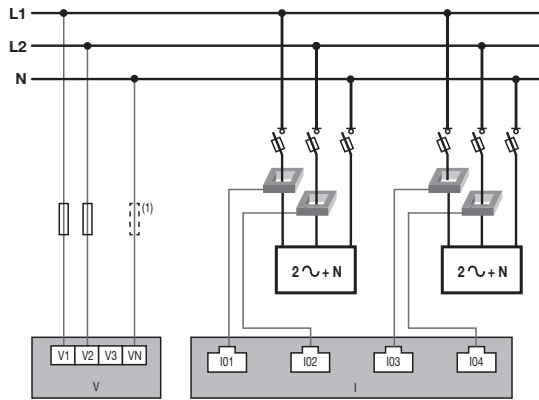

**Two-phase
2P – 1CT (x4)**

(4 two-phase loads)

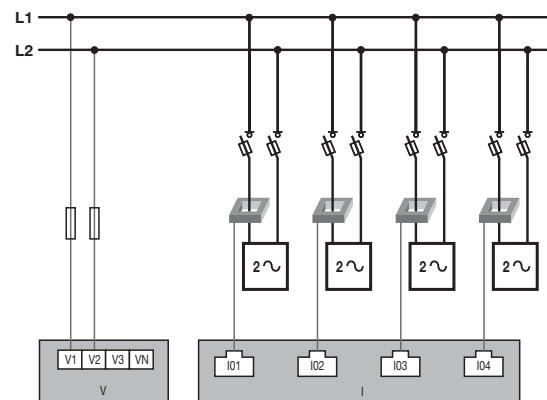

**Single-phase
1P+N – 1CT (x4)**

(4 single-phase loads)

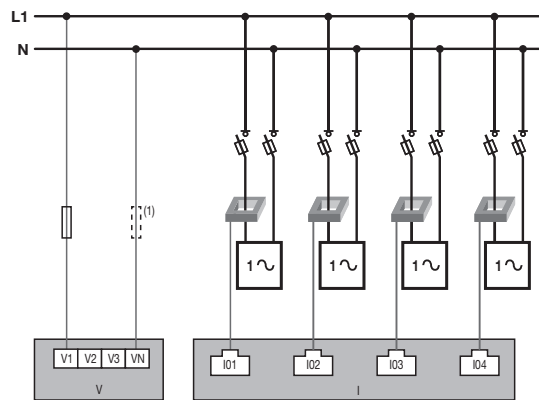

0.5 A gG / BS 88 2A gG / 0.5 A class CC fuse
For self-supply modules, a fuse must be added to the neutral.

 Fuse: 0.5 A gG / BS 88 2A gG / 0.5 A class CC

Notes relating to connections:

The **Easy Config** software can also be used to select numerous other configuration variants for the types of loads and associated network voltages.

3P – 2CT: this connection reduces the accuracy of the phases, the current for which is worked out by vector calculation, by 0.5%.

3P – 1CT: this connection requires a three-phase network that is perfectly balanced.

6.3.4. Connection of the functional earth

It is recommended that the functional earth is connected to guarantee optimum measuring accuracy and better emissivity/immunity for the electromagnetic compatibility (class B in conducted emission). Earth must not be used in a neutral IT system.

7. STATUS AND AUTO-ADDRESSING LEDES

7.1. Status LEDs

These LEDs can be used to find out the status of the product at any time.

The addressing button is used to automatically assign a Modbus address from the gateway.

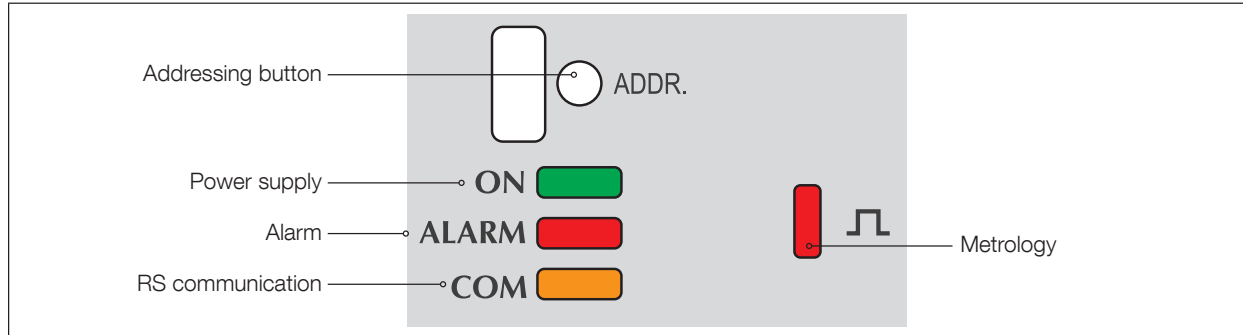

LED state	Fixed	Blinking	Pulse
ON	In operation	10 seconds - on request via a Modbus control to identify the device (remote screen, etc.)	1 second to start-up
/ALARM	An alarm (logical/analogue, etc.) is active (does not take priority if there is a setup alarm at the same time)	At least one setup alarm is active (current sensor disconnected, V/I not compatible, etc.)	1 second to start-up
COM	Addressing problem.	Address OK	1 second to start-up and when a frame received is processed
	-	-	Corresponds to the metrological pulse weight

7.2. Auto-addressing

Auto-addressing mode is used to automatically allocate addresses to products connected to the gateway. This mode is only compatible with DIRIS B and Digiware type PMDs. The addresses will be allocated manually on the other PMD (DIRIS A) and meters (COUNTIS).

Two modes are available:

- Mode 1 - Auto-detection and automatic addressing
- Mode 2 - Auto-detection and address selection

Mode 1 is without external equipment (see description below).

Mode 2 is carried out from a PC equipped with Easy Config. This mode is described in the Easy Config manual.

Description of mode 1

Flashing LED  LED on continuously 

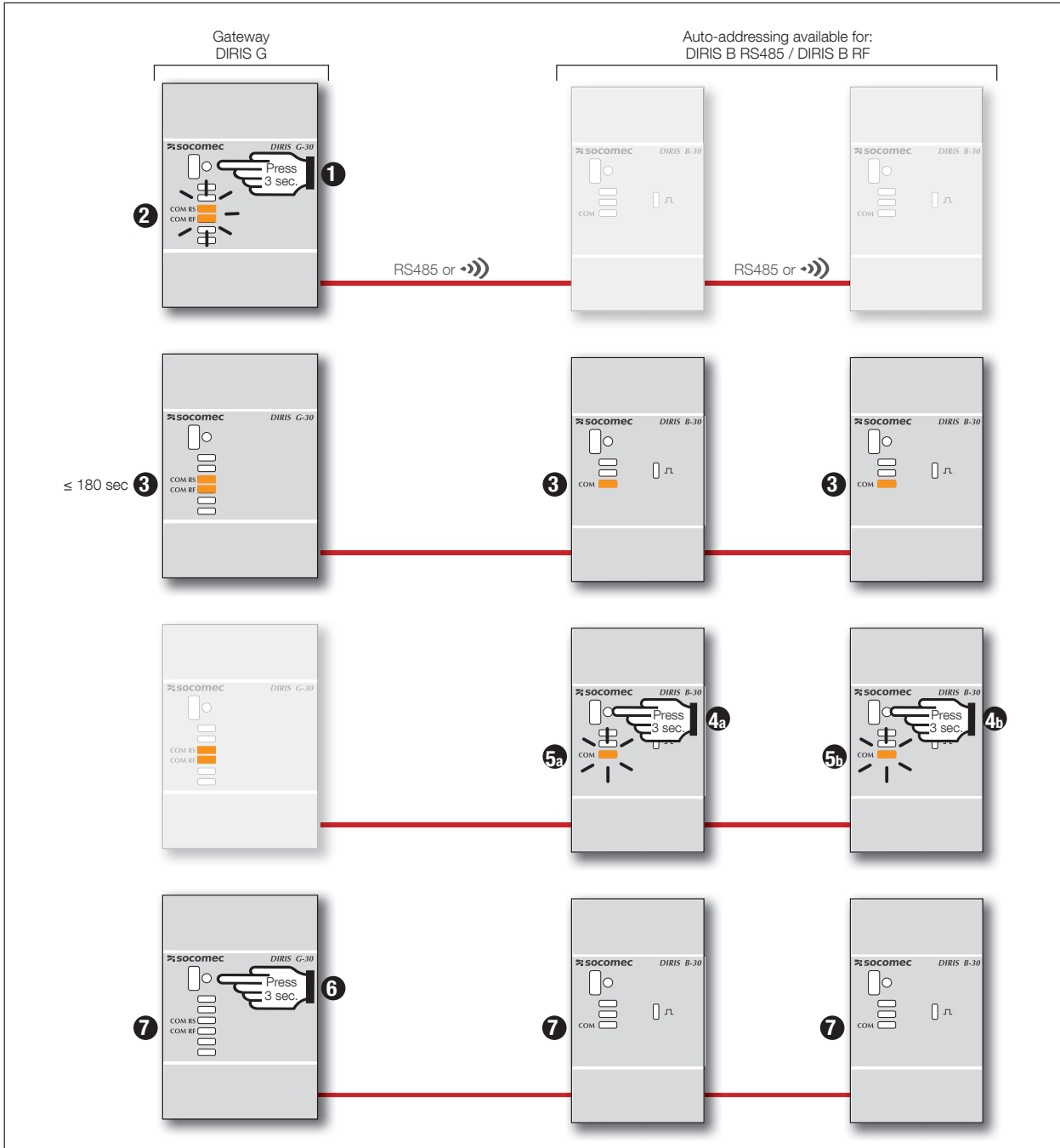

Note: During the auto-addressing process, the RS485 line is reserved for allocating addresses and no other exchange of data is possible at this time

8. COMMUNICATION

8.1. General information

Depending on the reference, the DIRIS B communicates via RS485 using the Modbus protocol or via a radio (RF) link. With a RS485 link, the DIRIS B-10 (ref.4829 0010) and DIRIS B-30 (ref.4829 0000) can be connected directly to a PC, to a PLC or to the DIRIS G-30, G-40, G-50 and G-60 gateways (see corresponding manual for more details) to use the data. With an RF link, the DIRIS B-30 RF (ref.4829 0002) communicates with the DIRIS G-40 and G-60 gateways in RS485/RF version (reference: 4829 0301 and 4829 0303).

Example of an installation integrating DIRIS B-30 RF, DIRIS B RS485 and other products with a DIRIS G-40 or G-60 gateway:

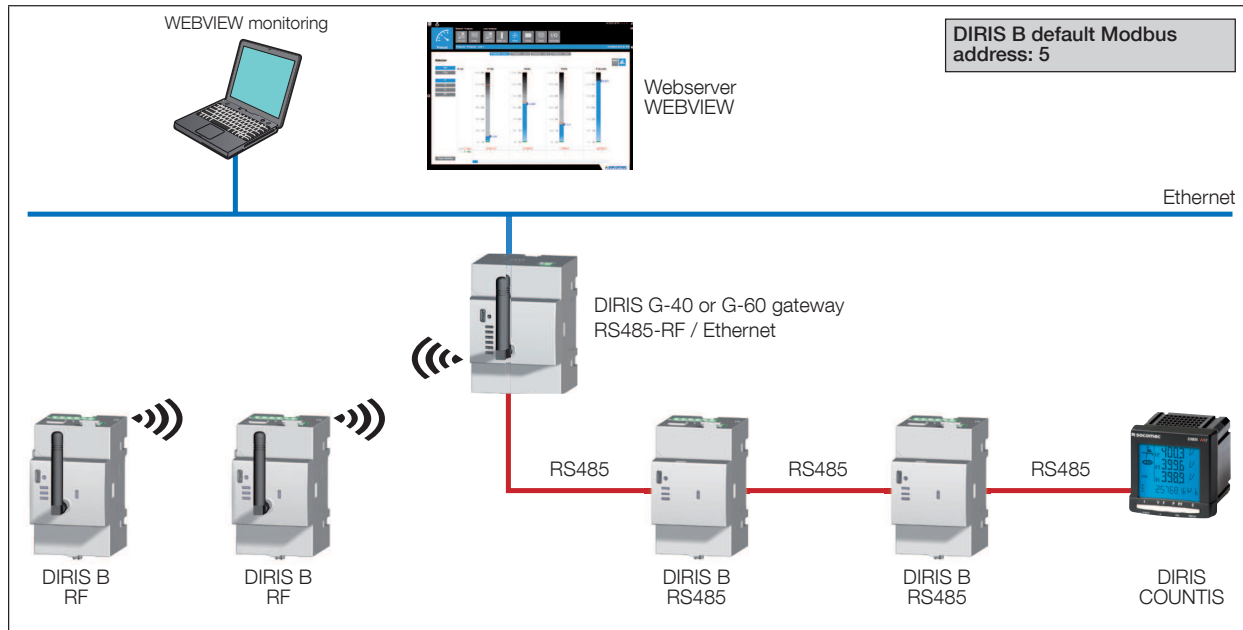

8.2. RS485 rules

RS485 communication is available on the DIRIS B-10 (ref. 4829 0010) and DIRIS B-30 RF (ref. 4829 0000). It is achieved via an RS485 serial link (2- or 3-wire) using the Modbus RTU protocol for using products from a PC, PLC or gateway.

The Modbus protocol requires a dialogue with a master/slave structure. The mode of communication is the RTU (Remote Terminal Unit). In a standard configuration, an RS485 link enables the interconnection of 32 products to a PC, a PLC or the gateway over a distance of 1200 metres.

Connection between the DIRIS B RS485 and the DIRIS G gateway:

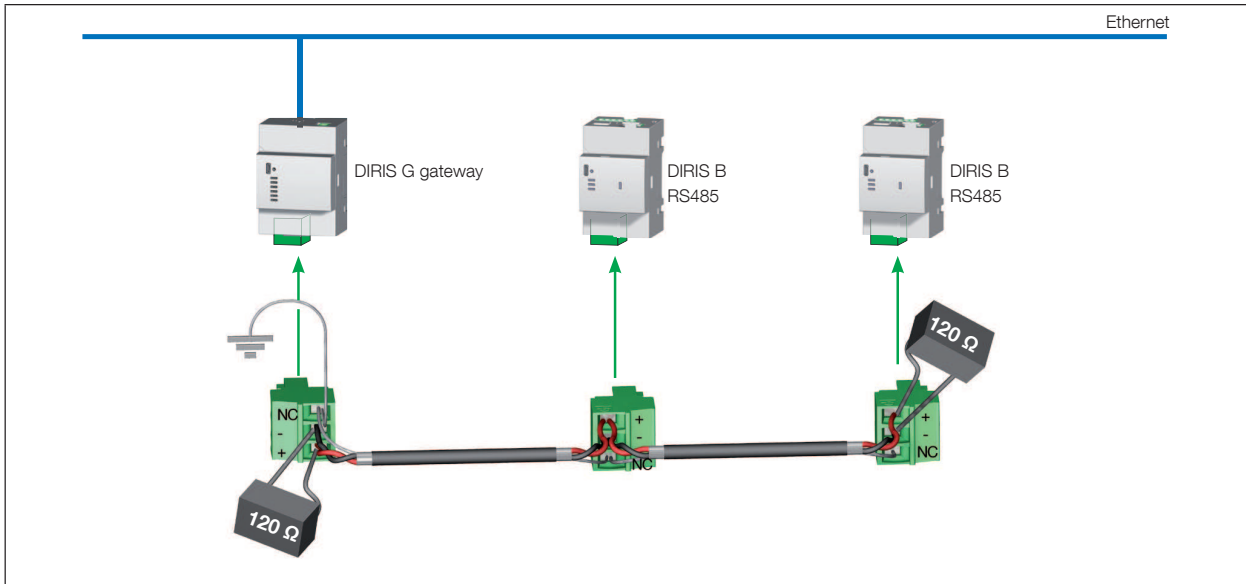

A LIYCY type connecting cable with a shielded twisted pair is required. In a disturbed environment or large network (in terms of length or number of products) the use of a type LIYCY-CY twisted pair with general shielding is recommended.

A 120-ohm resistor must be placed at both ends of the link.

A 120-ohm resistor is supplied with each DIRIS B and with each DIRIS G gateway.

8.3. Radio-frequency (RF) rules

Wireless radio-frequency (RF) communication is available on DIRIS B-30, ref. 4829 0002. The frames are transferred via a radio frequency in the bandwidth frequency 868MHz. The DIRIS B-30 which use wireless communication will be combined with the DIRIS G-40 and G-60 gateways in the RS485/RF version and will be seen as Modbus RTU slaves by these gateways.

These gateways collect data from the wireless DIRIS B-30 and also from the DIRIS B or other products (Countis, Diris...) with a cabled RS485 link. This data can then be transferred to a PC via an Ethernet link with Modbus TCP protocol.

The WEBVIEW web server embedded in the gateway offers advanced data Monitoring and Reporting functions (refer to the corresponding manual for more details).

The DIRIS B-30 equipped with a wireless communication link are particularly useful for using loads located in isolated, remote areas, without the need to set up a cabled communication link.

Example of an installation integrating DIRIS B-30 RF with a DIRIS G-40 or G-60 gateway:

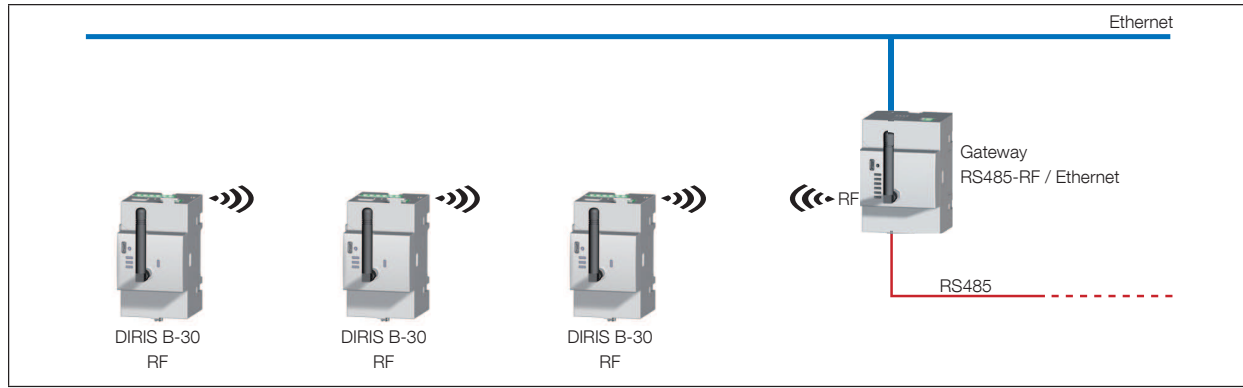

8.3.1. Installation

Only use antennae recommended by SOCOMEC.

The DIRIS B-30 RF communicates over a distance of 300 metres in free-field conditions.

The permitted occupancy rate depends on the frequency used. The frequency is selected using the Easy Config configuration tool.

The table below describes the permitted occupancy rate based on the selected frequency and the resulting maximum number of DIRIS B-30 RF which can be connected.

Channel no.	Frequency (MHz)	Permitted occupancy rate	Maximum number of DIRIS B-30 RF connected
420	868.1000	1%	16
436	868.3000	1%	16
452	868.5000	1%	16
472	868.7500	0.10%	3
488	868.9500	0.10%	3
504	869.1500	0.10%	3
534*	869.5250	10%	32
539	869.5875	10%	32

According to EN300 220: radiated radio and REC7003 emissions: use of the RF 868 MHz bandwidth.

Note: in order to observe a frequency spacing of 200 kHz, channels 534 and 539 cannot be used at the same time.
*Default channel.

8.3.2. EC Declaration of Conformity

The EC Declaration of Conformity for the DIRIS B is available here:

www.socomec.com/en/diris-b



8.4. Communication tables

The communication tables and associated explanations can be found on the documentations page for the DIRIS B on the SOCOMEC website at the following address:

www.socomec.com/en/diris-b

The communication tables are sent via Modbus.



9. CONFIGURATION

Configuration can be carried out using the Easy Config configuration software or directly from the remote display. The Easy Config software is used to configure the DIRIS B directly via RS485 or USB. Easy Config must be installed before using the USB connection.

If the DIRIS B is combined with the DIRIS G-30, G-40, G-50 or G-60 gateway, it can be configured through this via Ethernet or USB.

To set the parameters from the remote display, refer to the manual for the display.

9.1. Configuration using Easy Config

9.1.1. Connection modes

Configuration using Easy Config directly (USB)

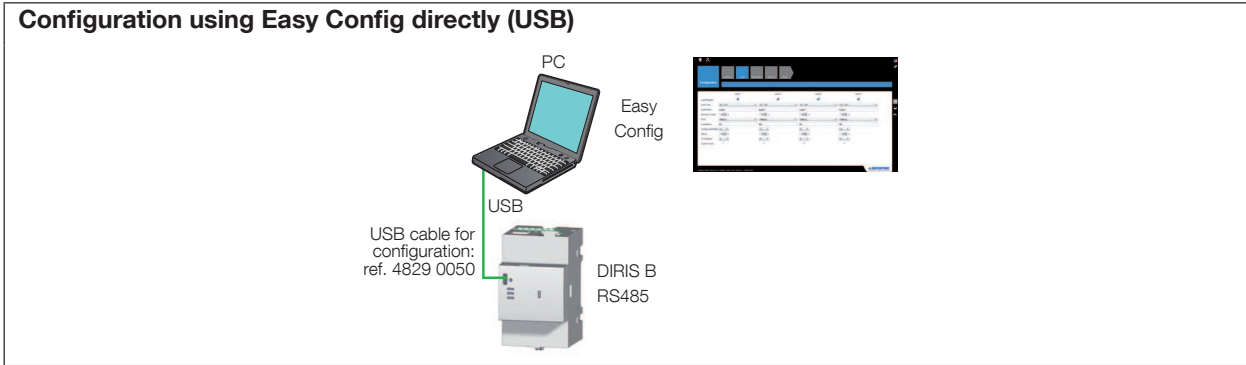

Configuration using Easy Config via a DIRIS G gateway (USB)

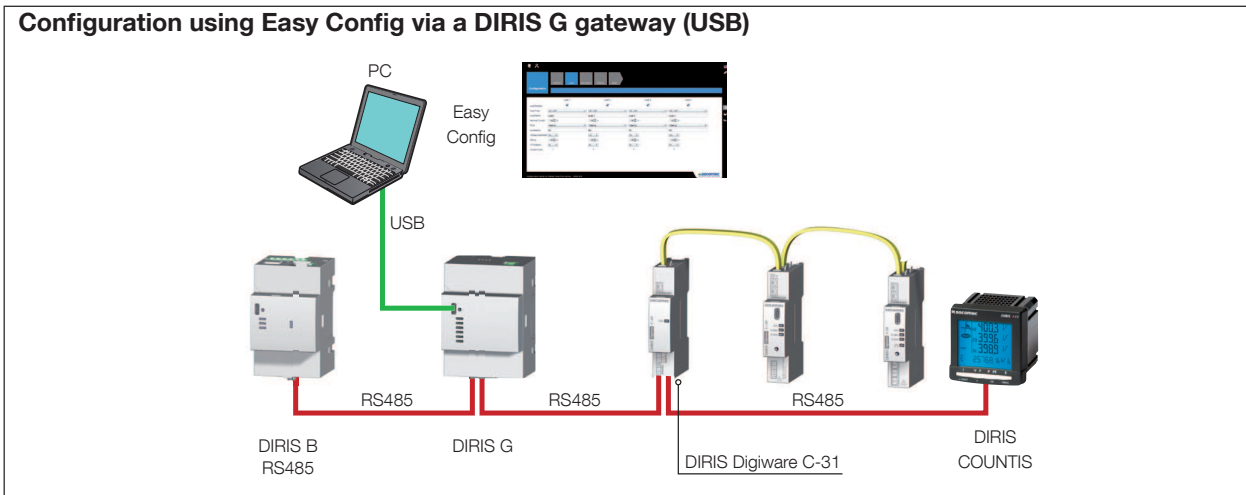

Configuration using Easy Config via a DIRIS G monitor (USB)

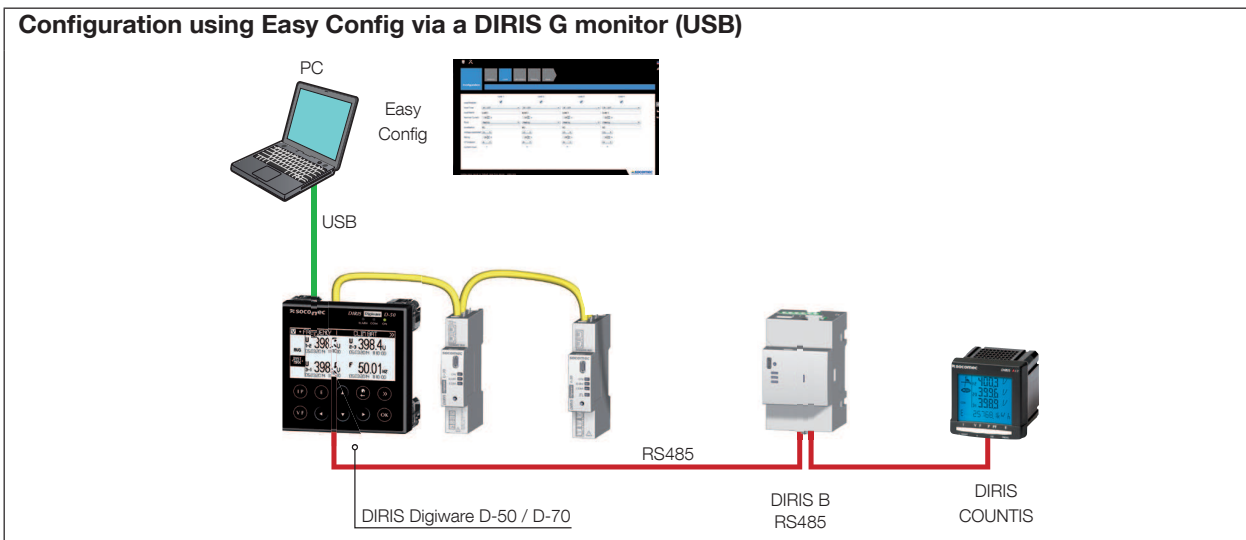

Configuration using Easy Config via a DIRIS G gateway (Ethernet)

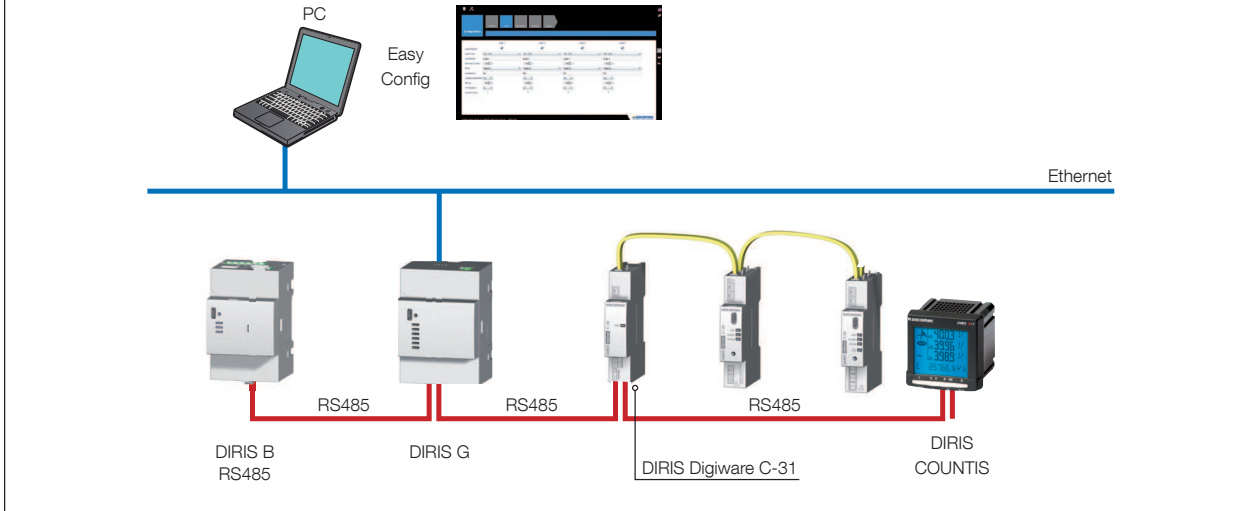

Configuration using Easy Config via a DIRIS D-50 / D-70 monitor (Ethernet)

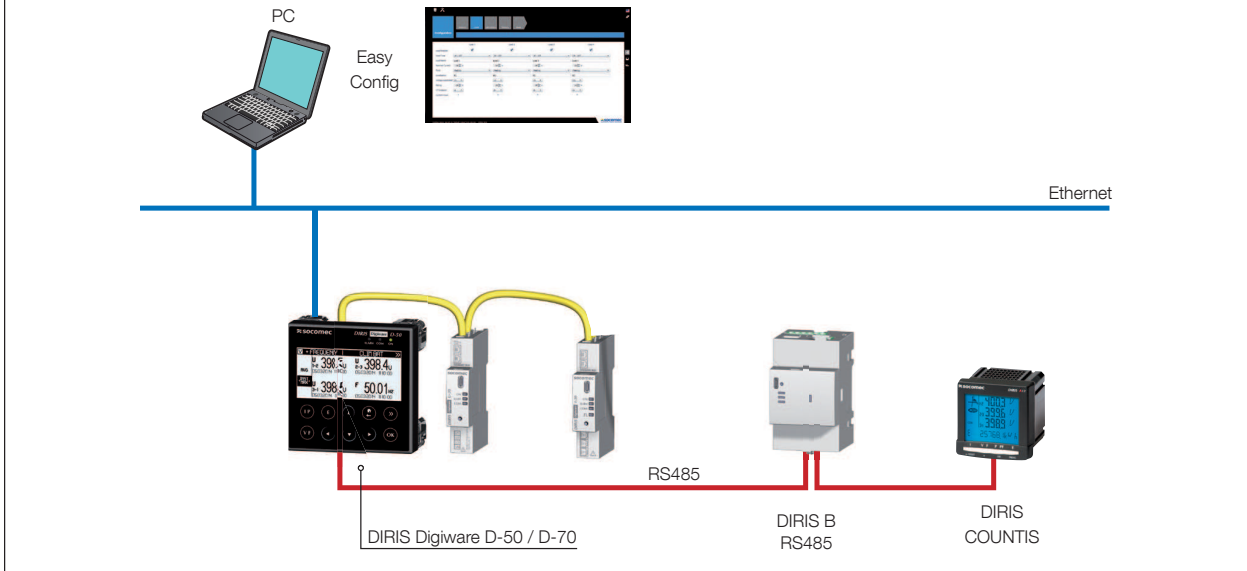

9.1.2. Using Easy Config

Easy Config is configuration software used to set product parameters easily and quickly. Parameters are set in successive steps:

Network → Loads → Measurement method → Values to be stored → Alarms → End configuration

(1)

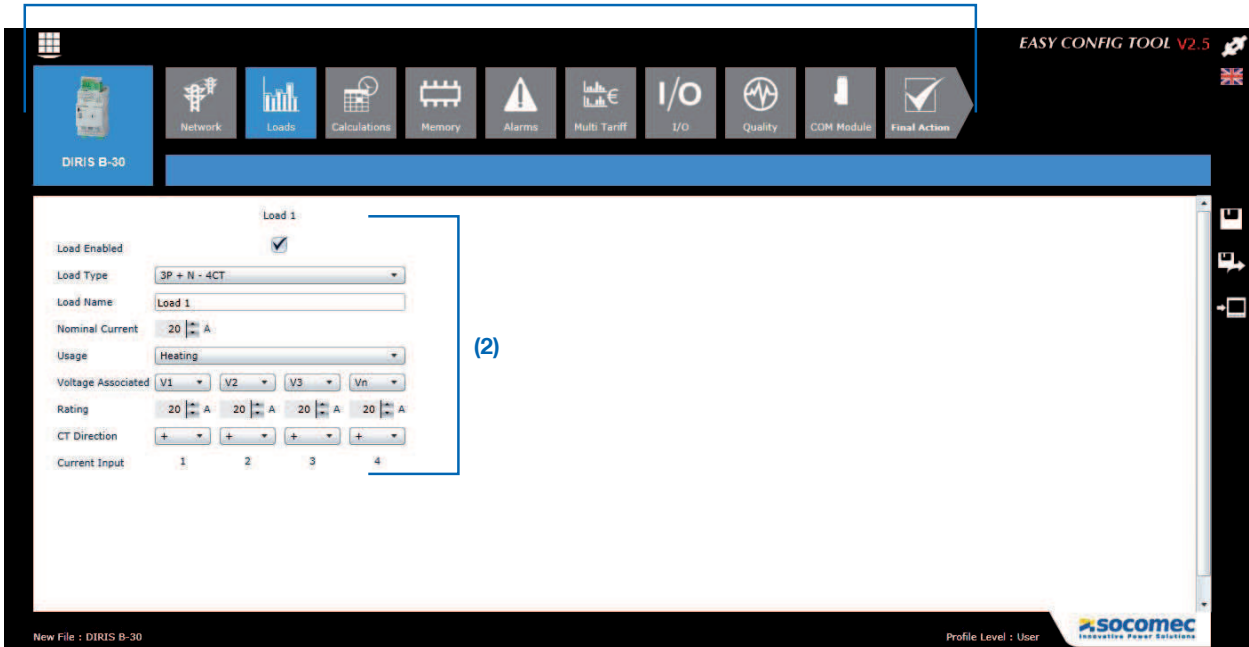

For each setting selected (1) a customised screen appears, depending on the connected product (2).

Network configuration

In the electrical network configuration menu, the user selects the type of network (three-phase, single-phase, etc.), the nominal voltage, the network frequency, the direction of phase rotation and whether or not a voltage transformer is used.

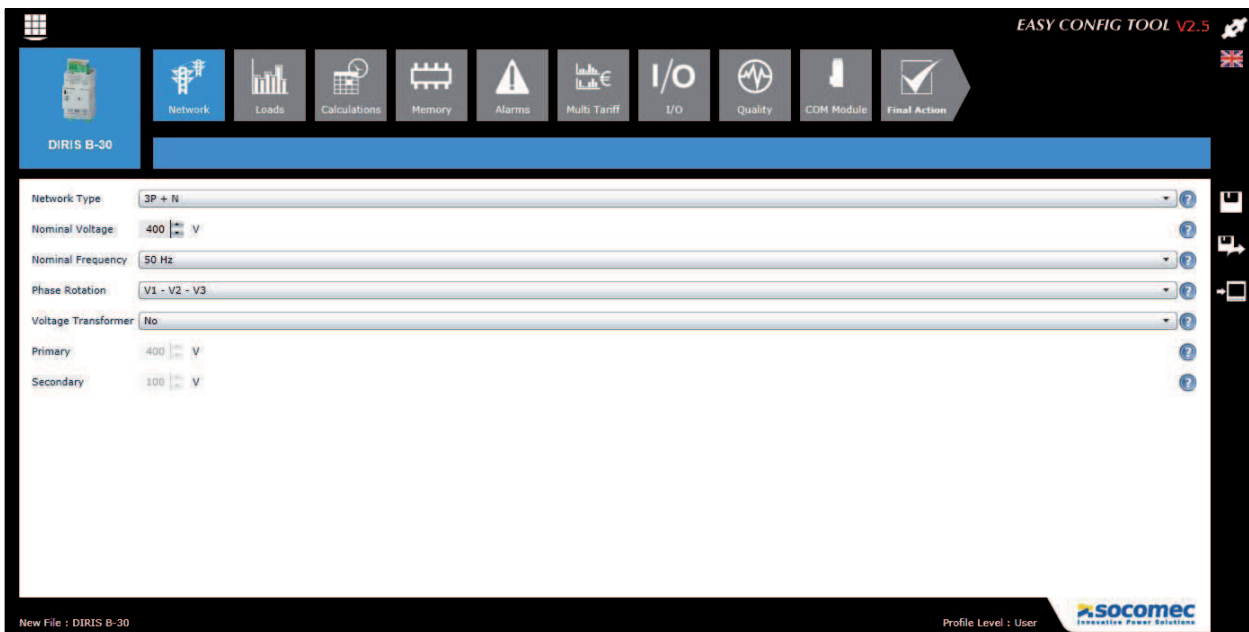

Configuring the loads

The number and type of loads can be accessed in the load configuration menu. The user can also define its nominal current, the name of the load, its usage and its location within the electrical installation.

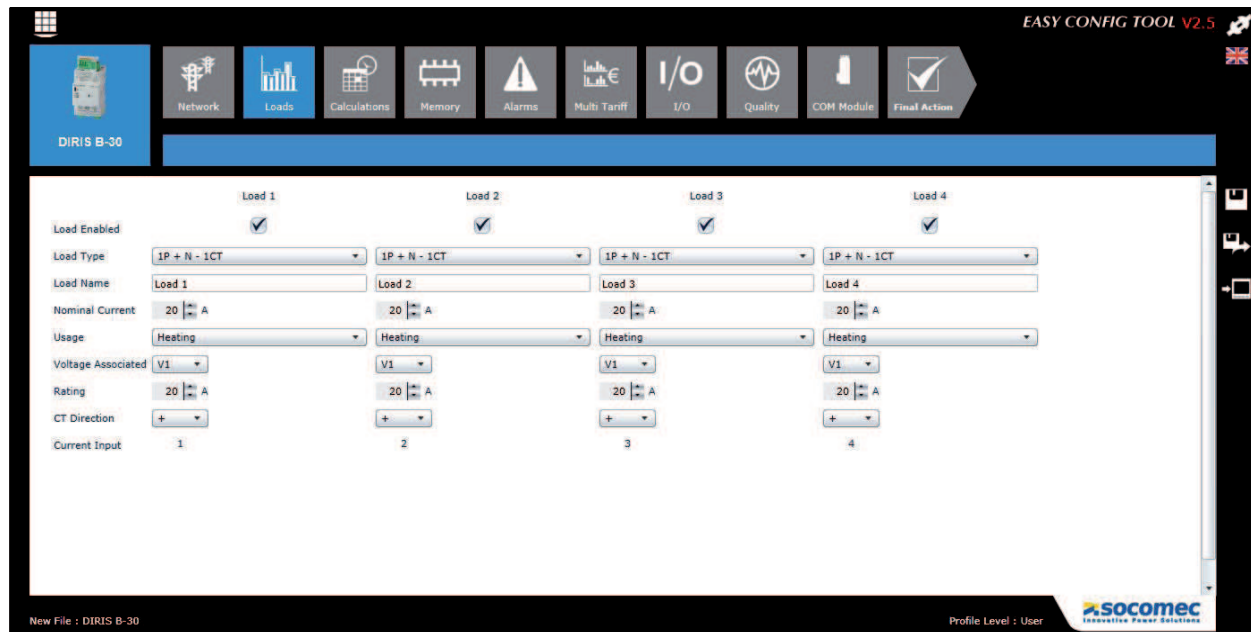

The screenshot shows the 'EASY CONFIG TOOL V2.5' interface for 'DIRIS B-30'. The 'Loads' menu is selected. The configuration table is as follows:

	Load 1	Load 2	Load 3	Load 4
Load Enabled	<input checked="" type="checkbox"/>	<input checked="" type="checkbox"/>	<input checked="" type="checkbox"/>	<input checked="" type="checkbox"/>
Load Type	1P + N - 1CT	1P + N - 1CT	1P + N - 1CT	1P + N - 1CT
Load Name	Load 1	Load 2	Load 3	Load 4
Nominal Current	20 A	20 A	20 A	20 A
Usage	Heating	Heating	Heating	Heating
Voltage Associated	V1	V1	V1	V1
Rating	20 A	20 A	20 A	20 A
CT Direction	+	+	+	+
Current Input	1	2	3	4

Calculation method

The calculation methods for the various electrical parameters and the integration time are defined in this screen.

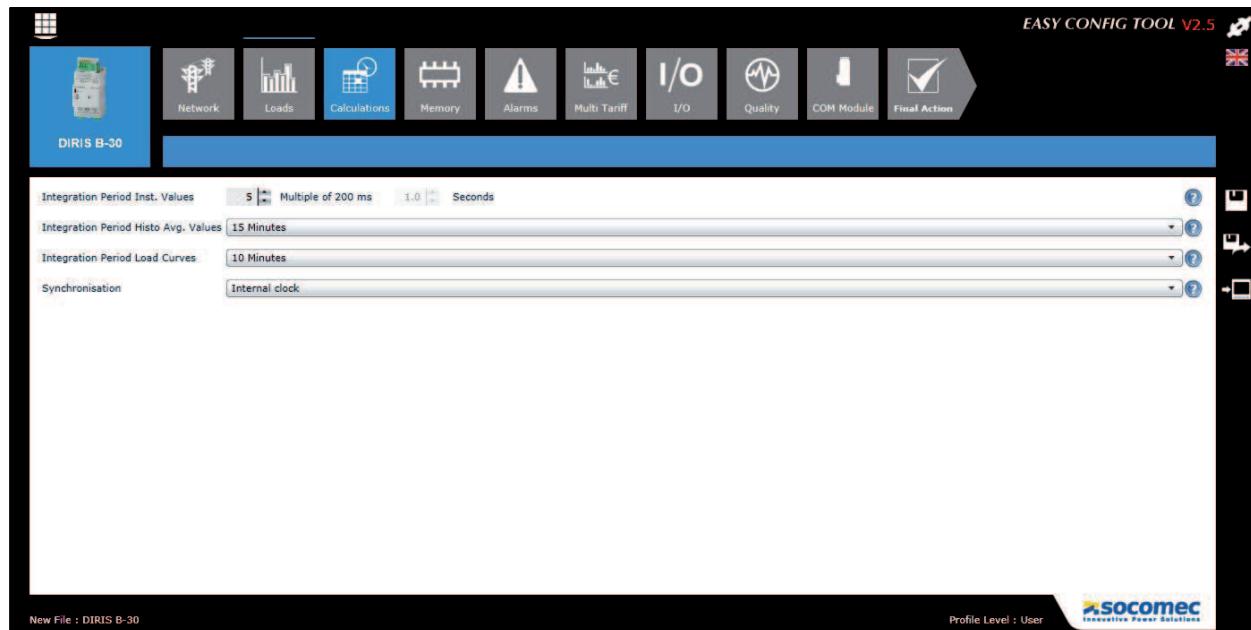

The screenshot shows the 'Calculations' menu selected in the 'EASY CONFIG TOOL V2.5' interface for 'DIRIS B-30'. The configuration parameters are:

- Integration Period Inst. Values: 5 (Multiple of 200 ms), 1.0 (Seconds)
- Integration Period Histo Avg. Values: 15 Minutes
- Integration Period Load Curves: 10 Minutes
- Synchronisation: Internal clock

Alarms

The type of alarm and the configuration are set in Easy Config, see section "10. ALARMS", page 49 for more details.

9.1.3. Synchronisation of products

From Easy Config, synchronisation is completed from an SNTP server or manually. The time may be displayed on connected products automatically based on a configurable update schedule.

The screenshot displays the 'EASY CONFIG TOOL V2.2' interface for configuring a DIRIS G-30/G-40/G-50/G-60 device. The configuration is organized into several sections:

- SNTP server settings:** Activation is set to 'Yes'. The SNTP server IP address is '0.0.0.0' and the SNTP Server Port is '123'.
- Slave Time Diffusion:** Automatic slaves time update is 'Yes'. Gateway time update frequency is '60 s' and Slaves time update frequency is '30 s'.
- Slaves Information Diffusion:** Slaves load curve synchronisation method is 'Disabled'. Slaves load curve integration time is '15 Min'. Slaves historical values synchronisation method is 'Disabled'. Slaves historical values integration time is '60 Min'.
- Date/Time:** Time Zone is set to 'UTC'.

At the bottom, there are two synchronization options: 'Automatic' (Sync from PC Date/Time) and 'Manual' (5/15/2014 3:04:28 PM) with a 'Send' button.



So that all connected products display the same time, use the DIRIS G gateway or the multipoint DIRIS Digiware D-50 / D-70 screen for synchronisation. Do not use the synchronisation function on a single-point DIRIS D-30 screen as part of a multiproduct configuration.

9.2. Configuration from the DIRIS D-30 remote display

9.2.1. Connection mode

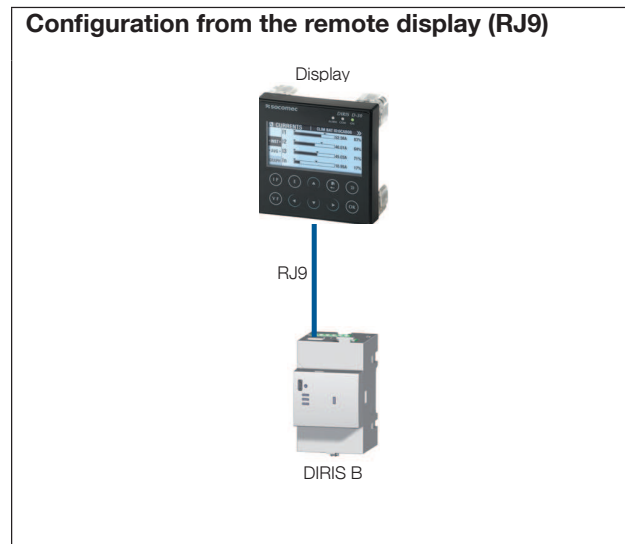

Refer to the manual for the DIRIS D-30 display for more details.

Connection cables for the remote display (RJ9):

Length (m)	Quantity	Reference
1.5	1	4829 0280
3	1	4829 0281

If the cables used are equivalent to SOCOMEC cables, ensure the specifications given in the recommendations section “6.1. Connecting the DIRIS B”, page 30 are observed, and that they are a maximum of 3 metres in length.

10. ALARMS

Alarms are available only on the DIRIS B-30 RS (ref. 4829 0000) and DIRIS B-30 RF (ref. 4829 0002).

10.1. Alarms upon events

On the DIRIS B-30 RS and RF, alarms can be generated when a threshold is exceeded for the electrical measurements, consumption, variations in level or change in input status. Also, combinations can be made on the alarms created.

up to 50 alarms detected are saved and timestamped; an alarm can have 3 distinct statuses: Alarm active, Alarm completed, Alarm completed and acknowledged. Alarms can be acknowledged either automatically or by user action, as required.

Up to 8 alarms for an electrical measurement are configured per item of equipment and 4 for changes in status of a digital input.

The alarms are configured via the Easy Config software.

10.1.1. Electrical parameters

- Alarm upon variation in the instantaneous or average value of an electrical value: Current, voltage, frequency, power, power factor, Cos phi, total harmonic distortion
- Selection of the hysteresis and high/low threshold
- Setting a time delay at the start and end of the alarm
- For the associated total harmonic distortion, voltage and current three-phase values, an alarm may be generated if the condition is fulfilled on a combination of phases:
 - On a single-phase: Phase1, Phase2, Phase3
 - On all the phases simultaneously: Phase1 and Phase2 and Phase3
 - On one phase of the three phases: Phase1 or Phase2 or Phase3

Example of configuring an alarm on the current via Easy Config:

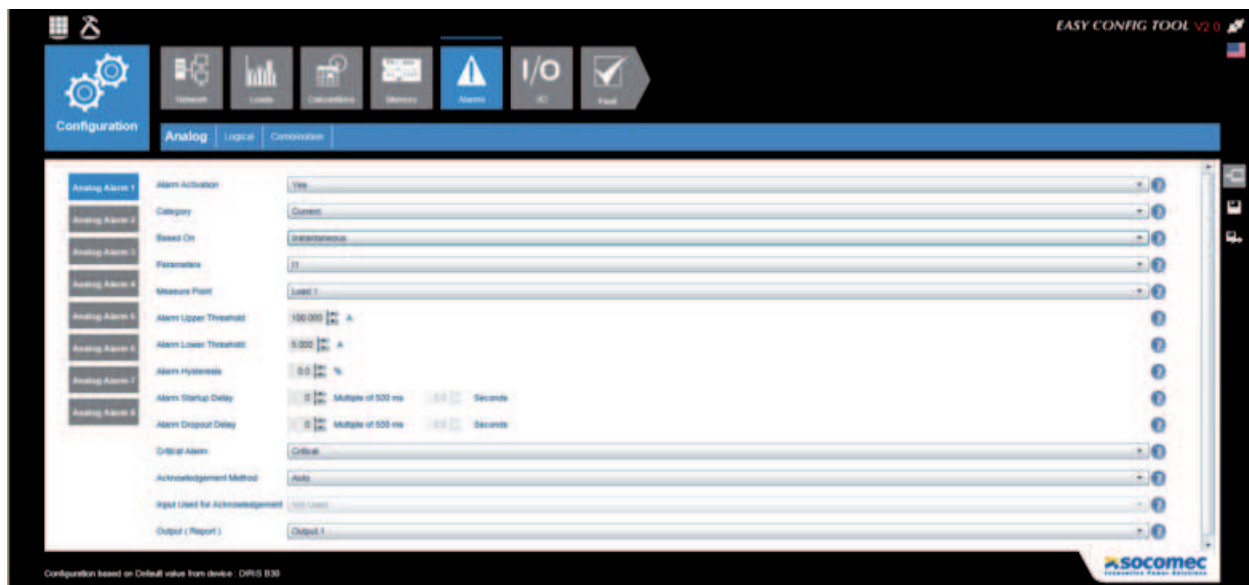

10.1.2. Voltage and current unbalance (in a three-phase network)

- Alarms on voltage unbalances: Unba, Unb
- Alarm upon current unbalance: Inba, Inb
- Selection of the hysteresis and high/low threshold
- Setting a time delay at the start and end of the alarm

10.1.3. EN 50160 voltage quality events

- Alarms on quality events for the voltage provided: voltage dips (Udip), temporary overvoltages (Uswl) and voltage outages (Uint), taking the occurrence into account: number, reference period.

10.1.4. Consumption

- Alarm on the energies: Ea+, Ea-, Er+, Er-, Eap (total or partial)
- Choice of a high (consumption too high) or low (consumption too low) threshold

10.1.5. Analogue inputs

- Alarm upon variations in the temperature or analogue input
- Selection of the hysteresis and high/low threshold
- Setting a time delay at the start and end of the alarm

10.1.6. Digital inputs

- Alarm upon change of status for a digital input
- Choice of a rising or falling edge
- Setting a time delay at the start and end of the alarm

Example of configuring an alarm on a digital input via Easy Config:

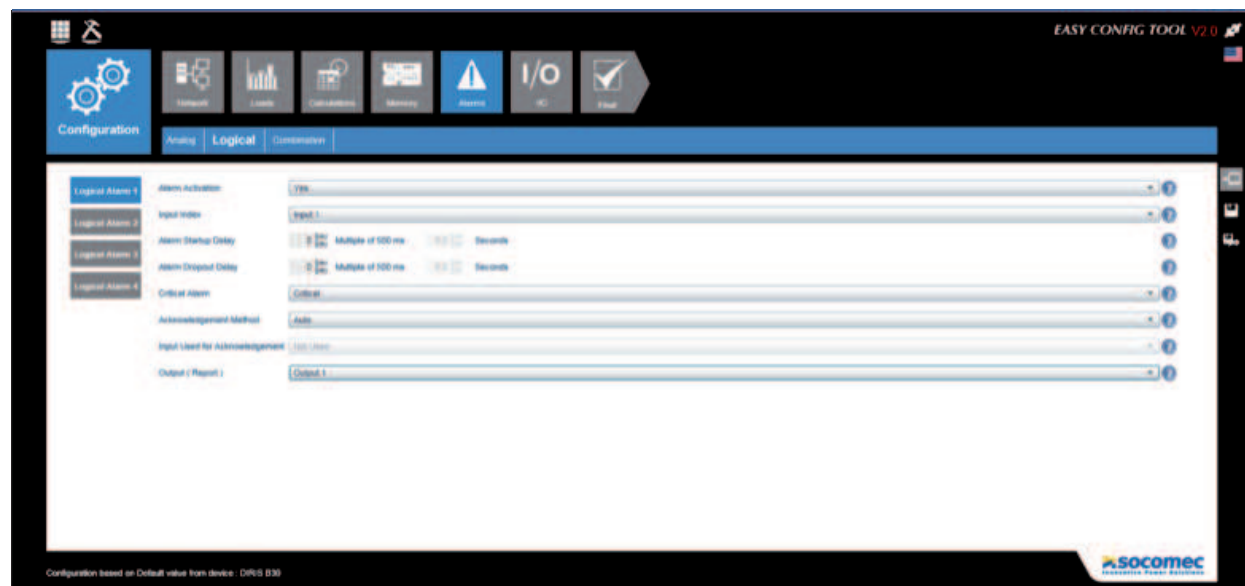

10.1.7. Combination of alarms

- 4 boolean combinations (OR, AND) on the defined alarms (electrical values, energy, inputs, etc.)

Example of configuring an alarm on a digital input via Easy Config:



10.2. Setup alarms

If an installation error is detected during setup, an alarm will be automatically generated.

10.2.1. Current/voltage compatibility

- Alarm upon connection error between the current and the voltage
- Requires a certain load level: $0.6 < PF < 1$ and $I > 2\% I_n$

10.2.2. Incorrect direction of rotation (three-phase network)

- Alarm upon identification of the incorrect direction of phase rotation (for example 3-2-1 instead of 1-2-3)

10.2.3. Faulty current sensor

- Alarm for detecting the absence of a current sensor

10.3. Setting up alarms

The installation alarms are automatically detected and alarms upon events are configured with the Easy Config software.

There are several ways of identifying the presence of an alarm:

10.3.1. ALARM LED on front

- Blinking: Setup alarm
- Fixed: Alarm upon event (takes priority if there is a commissioning alarm at the same time)

10.3.2. Activation of an output

- If an output is present on the product, it can be activated when an alarm is detected

10.3.3. Activation of an input

- If an input is present, the alarm can be acknowledged from this input. Acknowledgement of an alarm can only be taken into account if the alarm is complete

10.3.4. RS485 Modbus

- Information on the alarms with timestamping available via the RS485 communication bus
- Sends alarm acknowledgement

10.3.5. Display and WEBVIEW

- Information on the alarms with timestamping
- Sends alarm acknowledgement

11. FEATURES

11.1. DIRIS B features

11.1.1. Mechanical features

Casing type	DIN-rail mounting module and base
Casing protection index	IP20 / IK06
Index of protection of front side	IP40 on the nose in modular assembly / IK08
Sealing for the voltage and current connections	Sealable enclosure option for DIRIS B and sensors: ref: 4829 0597
Weight	DIRIS B-10: 160 g DIRIS B-30 RS: 160 g DIRIS B-30 RF: 175 g

11.1.2. Electrical specifications

Auxiliary power supply	
Alternative voltage	110-230 VAC $\pm 15\%$ (Ph/N or Ph/Ph) Cat III
Frequency	50/60 Hz
Power consumption	< 2VA without display, < 6VA with display DIRIS D-30
Connection	Removable spring-cage terminal block, 2x 2 positions, 0.5 - 2.5 mm ² solid cable or 0.25 - 1.5 mm ² stranded cable with end piece

11.1.3. Input characteristics

Input	
Number	2
Type / Power supply	Optocoupler internal (12VDC $\pm 10\%$) or external (10-30VDC $\pm 10\%$) polarisation
Input function	Logic status, pulse meter or synchronisation pulse status (input 1)
Connection	Removable screw terminal block, 4 positions, stranded or solid 0.14 - 1.5 mm ² cable

11.1.4. Measuring characteristics

Measurement accuracy	
Accuracy	According to IEC 61557-12 PMD DD classification in association with specified census (TE, TR, TF)
Measuring energy and power	
Active energy and active power accuracy	0.2 DIRIS B class only Class 0.5 with TE or TF sensors Class 1 with TR sensors
Accuracy of reactive energy	Class 2 with TE, TR or TF sensors
Power factor measurement	
Accuracy	Class 0.5 with TE or TF sensors Class 1 with TR sensors
Voltage measurement	
Characteristics of the network measured	50-300 VAC (Ph/N) - 87-520 VAC (Ph/Ph) - CAT III
Frequency range	45 - 65Hz
Frequency accuracy	Class 0.02
Network type	Single-phase/ Two-phase / Two-phase with neutral / Three-phase / Three-phase with neutral

Measurement by voltage transformer	Primary: 400 000 VAC Secondary: 60, 100, 110, 173, 190 VAC
Input consumption	≤ 0,1 VA
Permanent overload	300 VAC Ph/N
Accuracy of voltage measurement	Class 0.2
Connection	Removable spring-cage terminal block, 2 x 6 positions, 0.5 - 2.5 mm ² solid cable or 0.25 - 1.5 mm ² stranded cable with end piece
Measurement of currents	
Number of current inputs	4
Associated current sensors	Solid TE, split-core TR, flexible TF current sensors
Accuracy	0.2 DIRIS B class only Class 0.5 with TE or TF sensors Class 1 with TR sensors
Connection	Specific Socomec cable with RJ12 connectors

11.1.5. Communication specifications

DIRIS B-30 RS485	
Connection	RS485
Connection type	2 - 3 half duplex wires
Protocol	Modbus RTU
Baudrate	1200 - 115200 bauds
Function	Data configuration and reading
Connection	Removable screw terminal block, 3 positions, stranded or solid 0.14 - 1.5 mm ² cable
DIRIS B-30 RF	
Connection	Wireless radio-frequency
Frequency range	868 MHz (low frequency: 868.1 MHz and high: 869.5875 MHz)
Baudrate	38400 bauds
Function	Configuration and reading of data via the DIRIS G-40 or G-60 gateway
USB	
Connection	USB 2
Protocol	Modbus RTU on USB
Function	DIRIS B configuration
Connection	Type B micro USB connector

11.1.6. Environmental specifications

Operating temperature	-10 - +70°C (IEC 60068-2-1/IEC 60068-2-2)
Storage temperature	-25 - +85°C (IEC 60068-2-1/IEC 60068-2-2)
Operating humidity	55°C / 97% HR (IEC 60068-2-30)
Operating altitude	< 2,000 m
Vibration	0.35 mm, 25 Hz, 20 min/axe (IEC 61557-12)
Rated impulse voltage	IEC 60947-1 V. IMP: 6.4kV
PEP ecopassport - ISO 14025	DIRIS B: SOCO-2014-01-v1-fr, SOCO-2014-01-v1-en
Impact resistance	Front panel: 5J - casing: 1J (IEC 61010-1 Ed 3.0)

11.1.7. Electromagnetic compatibility

Immunity to electrostatic discharges	IEC 61000-4-2 LEVEL III
Immunity to radiated radio-frequency fields	IEC 61000-4-3 LEVEL III
Immunity to electrical fast transients/bursts	IEC 61000-4-4 LEVEL IV
Immunity to impulse waves	IEC 61000-4-5 LEVEL IV
Immunity to conducted disturbances	IEC 61000-4-6 LEVEL III
Immunity to power frequency magnetic fields	IEC 61000-4-8 400A/m LEVEL IV
Conducted emissions	CISPR11 Group1 - CLASS B
Radiated emissions	CISPR11 Group1 - CLASS B
Immunity to voltage dips and short interruptions	IEC 61000-4-11 LEVEL III

11.1.8. Safety

Safety	Compliance with Low Voltage Directive 2006/95/EC of 12th December 2006 (EN 61010-1:2010)
Insulation	Installation category III (300VAC Ph/N), degree of pollution 2
UL	UL 61010-1 conformity

11.1.9. Service life

MTTF (mean time to failure)	> 100 years
-----------------------------	-------------

11.2. DIRIS O optional modules characteristics

Mechanical features	
Casing type	Modular for DIN rail mounting
Power supply⁽¹⁾	
Alternative voltage	110-230 VAC $\pm 15\%$
Frequency	50/60 Hz
Connection	Removable spring-cage terminal block, 2x 2 positions, 0.5 - 2.5 mm ² solid cable or 0.25 - 1.5 mm ² stranded cable with end piece
<i>(1) No power supply to DIRIS O-it.</i>	
DIRIS O-iod - 2 digital inputs/2 digital outputs	
Number of inputs	2 per optional module - 4 optional modules max.
Type	Optocoupler internal (12VDC $\pm 10\%$) or external (10-30VDC $\pm 10\%$) polarisation
Function	Logic status or pulse meter
Input connection	Removable screw terminal block, 4 positions, stranded or solid 0.14 - 1.5 mm ² cable (max. length 1000 m)
Number of outputs	0 output that can be used with DIRIS G
Type	Relay / 230 V $\pm 15\%$ - 1A
Function	Configurable alarm (current, power, etc.) on threshold overruns or remote controlled status
Output connections	2 removable screw terminal blocks, 2 x 2 positions, stranded or solid 0.14 - 1.5 mm ² cable
UL	UL 61010-1 conformity
DIRIS O-ioa - 2 analogue inputs/2 analogue outputs	

Number of inputs	2 per optional module - 4 optional modules max.
Type	4-20 mA
Function	Connection of analogue sensors (pressure, humidity, temperature, etc.)
Input connection	Removable screw terminal block, 4 positions, stranded or solid 0.14 - 1.5 mm ² cable
Number of outputs	2 per optional module - 4 optional modules max.
Type	4-20 mA
Function	Sends an image of the measurements (power, currents, etc.) to automated machines
Output connection	Removable screw terminal block, 4 positions, stranded or solid 0.14 - 1.5 mm ² cable
UL	UL 61010-1 conformity
DIRIS O-it - 3 temperature inputs	
Number of inputs	3 external inputs + 1 ambient measurement Max 1 optional module
Dynamic	-20 °C to 150 °C
Type	PT100 or PT1000
Function of inputs 1, 2 and 3	Temperature measurement
Connection	3 removable screw terminal blocks, 3 x 4 positions, stranded or solid 0.14 - 1.5 mm ² cable (max. length 3 m)
UL	UL 61010-1 conformity
DIRIS O-m - RS485 communication	
Connection	RS485 2 - 3 half duplex wires
Protocol	Modbus RTU
Baudrate	1200 - 115200 bauds
Function	Additional RS485 communication
Connection	Removable screw terminal block, 3 positions, stranded or solid 0.14 - 1.5 mm ² cable
DIRIS O-p - PROFIBUS communication	
Connection	RS485
Protocol	PROFIBUS DPV1
Start-up time	35 s
Function	PROFIBUS communication
Connection	SubD9 connector
DIRIS O-b/ip - BACnet IP communication	
Protocol	BACnet IP
Baudrate	10 - 100 Mbit/s
Start-up time	1 min 15 s
Function	BACnet IP communication
Connection	RJ45 port
DIRIS O-b/mstp - BACnet MSTP communication	
Connection	RS485
Protocol	BACnet MSTP
Baudrate	9600 - 76800 bauds
Start-up time	1 min 15 s
Function	BACnet MSTP communication
Connection	Removable screw terminal block, 5 positions, stranded or solid 0.2 - 2.5 mm ² cable

11.3. DIRIS D-30 display characteristics

11.3.1. Mechanical features

Type of screen	Capacitive touch-screen technology, 10 keys
Screen resolution	350 x 160 pixels
Weight (g)	160

11.3.2. Single product connection

RJ9	Self-powered and data
Micro-USB	Upgrade
Degree of protection	IP65 (front)

11.3.3. Electrical specifications

Power supply	24 VDC +10 % / -20 %
Power consumption	2 VA

11.3.4. Environmental specifications

Storage temperature	-20 to +70°C
Operating temperature	-10 to +55°C
Humidity	95% at 40°C
Installation category	CAT III
Degree of pollution	2

11.4. TE, TR and RF sensor features

TE - closed sensor TE-18 to TE-90							
Model	TE-18	TE-18	TE-25	TE-35	TE-45	TE-55	TE-90
Nominal current range I _n (A)	5 - 20	25 - 63	40 - 160	63 - 250	160 - 630	400 - 1000	600 - 2000 ⁽¹⁾
Actual measured current range (A)	0.1 - 24	0.5 - 75	0.8 - 192	1.26 - 300	3.2 - 756	8 - 1200	12 - 2200
Max. current (A)	24	75.6	192	300	756	1200	2400
Weight (g)	24	24	69	89	140	187	163
Max. voltage	300 V					600V	
Rated withstand voltage	3 kV					3.6 kV AC 1 min	
Frequency	50/60 Hz						
Intermittent overload	10x I _n in 1 second					40x I _n in 0.5 sec	
Measurement category	CAT III						
Protection degree	IP30 / IK06					IP30	
Operating temperature	-10 - +70°C						
Storage temperature	-25 - +85°C						
Relative humidity	95% RH without condensation						
Altitude	< 2,000 m						
PEP ecopassport - ISO 14025	TE sensors: SOCO-2014-03-v1-fr, SOCO-2014-03-v1-en						
UL	UL 61010						
Connection	SOCOMEK RJ12 cable, straight, twisted pair, unshielded, 300V cat.III. -40/+85°C.						
<i>⁽¹⁾ > 2000 A with 5A TC adapter.</i>							
TR - split-core sensor							
Model	TR-10	TR-16	TR-24	TR-36			
Nominal current range I _n (A)	25 - 75	32 - 100	63 - 200	200 - 600			
Actual measured current range (A)	0.5 - 90	0.64 - 120	1.26 - 200	4 - 720			
Max. current (A)	90	120	240	720			
Weight (g)	74	117	211	311			
Max. voltage	300 V						
Rated withstand voltage	3 kV						
Frequency	50/60 Hz						
Intermittent overload	10x I _n in 1 second						
Measurement category	CAT III						
Protection degree	IP20 / IK06						
Operating temperature	-10 - +70°C						
Storage temperature	-25 - +85°C						
Relative humidity	95% RH without condensation						
Altitude	< 2,000 m						
PEP ecopassport - ISO 14025	TR sensors: SOCO-2014-04-v1-fr, SOCO-2014-04-v1-en						
UL	UL 61010						
Connection	SOCOMEK RJ12 cable, straight, twisted pair, unshielded, 300V cat.III. -40/+85°C.						

TF - Flexible current sensor			
Model	TF-55	TF-120	TF-300
Nominal current range I _n (A)	150 - 600	500 - 2000	1600 - 6000
Actual measured current range (A)	3 - 720	10 - 2400	32 - 7200
Weight (g)	114	142	220
Max. voltage	600 V		
Rated withstand voltage	3.6 kV		
Frequency	50 / 60 Hz		
Intermittent overload	10x I _n in 1 second		
Measurement category	CAT III		
Protection degree	IP30 / IK07		
Operating temperature	-10 - +70°C		
Storage temperature	-25 - +75°C		
Relative humidity	95% RH without condensation		
Altitude	< 2,000 m		
UL	UL 61010 conformity		
Connection	SOCOMEK RJ12 cable, straight, twisted pair, unshielded, 300V cat.III. -40/+85°C.		

12. PERFORMANCE CLASSES

Performance classes are drawn up in compliance with IEC 61557-12 version 1 (08/2007)

Classification of the DIRIS B	DD in combination with specified sensors (TE, TR, TF)
Temperature	K55
Overall operating performance class for active power or active energy	0.5 in combination with TE or TF solid-core sensors 1 in combination with TR split-core sensors

12.1. Specification of the characteristics

Symbol	Function	Overall operating performance class for DIRIS B + associated sensors* (TE, TR, TF) in compliance with IEC 61557-12	Measurement range
Pa	Total active power	0.2% DIRIS B only 0.5 with TE or TF sensors 1 with TR sensors	10% ... 120% In 2% ... 120% In 2% ... 120% In
Q_A, Q_V	Total reactive power (arithmetic, vectorial)	1 with TE, TR or TF sensors	5% ... 120% In
S_A, S_V	Total apparent power (arithmetic, vectorial)	0.5 with TE or TF sensors 1 with TR sensors	10% ... 120% In
Ea	Total active energy	0.2% DIRIS B only 0.5 with TE or TF sensors 1 with TR sensors	10% ... 120% In 2% ... 120% In 2% ... 120% In
Er_A, Er_V	Total reactive energy (arithmetic, vectorial)	2 with TE, TR or TF sensors	5% ... 120% In
Eap_A, Eap_V	Total apparent energy (arithmetic, vectorial)	0.5 with TE or TF sensors 1 with TR sensors	10% ... 120% In
f	Frequency	0.02	45 ... 65 Hz
I, IN	Phase current, measured neutral current	0.2 DIRIS B only 0.5 with TE or TF sensors 1 with TR sensors	5% ... 120% In 10% ... 120% In 10% ... 120% In
INc	Calculated neutral current	1 with TE or TF sensors 2 with TR sensors	10% ... 120% In
U	Voltage (Lp-Lg or Lp-N)	0.2	50 ... 300 VAC Ph/N
PF_A, PF_V	Power factor (arithmetic, vectorial)	0.5 with TE or TF sensors 1 with TR sensors	0.5 lagging to 0.8 leading
Pst, Plt	Flicker (short-term, long-term)	-	-
Udip**	Voltage dip (Lp-Lg or Lp-N)	0.5	-
Uswl**	Temporary overvoltages (Lp-Lg or Lp-N)	0.5	-
Uint**	Voltage outage (Lp-Lg or Lp-N)	0.2	-
Unba	Voltage amplitude unbalance (Lp-N)	0.5	-
Unb	Voltage phase and amplitude unbalance (Lp-Lg or Lp-N)	0.2	-
THDu, THD-Ru	Total harmonic distortion rate of the voltage (relative to the fundamental, relative to the efficient value)	1	Orders 1 to 63
Uh**	Voltage harmonics	1	-
THDi, THD-Ri	Total harmonic distortion rate of the current (relative to the fundamental, relative to the efficient value)	1 with TE, TR or TF sensors	Orders 1 to 63
Ih**	Current harmonics	1 with TE, TR or TF sensors	-
Msv	Centralised remote control signals	-	-

*With SOCOMEC connection cables.

** Available only with the DIRIS B-30 RS (4829 0000) and DIRIS B-30 RF (4829 0002).

12.2. Evaluation of the power supply quality

Symbol	Function	Overall operating performance class for DIRIS B + associated sensors (TE, TR, TF) in compliance with IEC 61557-12	Measurement range
f	Frequency	0.02	45 ... 65 Hz
I, IN	Phase current, measured neutral current	0.2 DIRIS B only 0.5 with TE or TF sensors 1 with TRsensors	5% ... 120% In 10% ... 120% In 10% ... 120% In
INc	Calculated neutral current	1 with TE or TF sensors 2 with TRsensors	10% ... 120% In
U	Voltage (Lp-Lg or Lp-N)	0.2	50 - 300 VAC Ph/N
Pst, Plt	Flicker (short-term, long-term)	-	-
Udip**	Voltage dip (Lp-Lg or Lp-N)	0.5	-
Uswl**	Temporary overvoltages (Lp-Lg or Lp-N)	0.5	-
Uint**	Voltage outage (Lp-Lg or Lp-N)	0.2	-
Unba	Voltage amplitude unbalance (Lp-N)	0.5	-
Unb	Voltage phase and amplitude unbalance (Lp-Lg or Lp-N)	0.2	-
Uh**	Voltage harmonics	1	-
Ih**	Current harmonics	1 with TE, TR or TF sensors	-
Msv	Centralised remote control signals	-	-

** Available only with the DIRIS B-30 RS (4829 0000) and DIRIS B-30 RF (4829 0002).

CORPORATE HQ CONTACT:
SOCOMECSAS
1-4 RUE DE WESTHOUSE
67235 BENFELD, FRANCE

<http://www.socomec.com>



546 770 A - EN - 01/17

 **socomec**
Innovative Power Solutions