

CRITO®

Schienen-Längsverbinding bis 630 A

busbar connecting terminal up to 630A

Unión de barras hasta 630 A

Jonction longitudinale d'éclissage 630 A

Connessione longitudinale per barre 630 A

母线加长连接夹 630 A

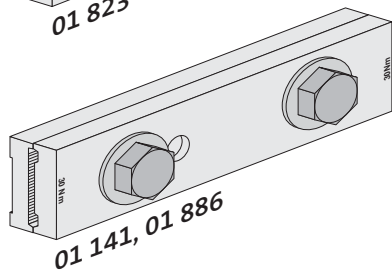
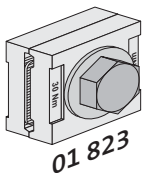
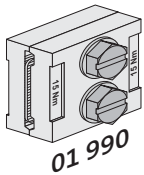

Achtung: Vor Installations- oder Servicearbeiten Stromversorgung unterbrechen, um Unfälle zu vermeiden. Die Geräte müssen in einem passenden Gehäuse eingebaut und gegen Verschmutzung geschützt werden. Inbetriebsetzung undWartung nur durch Fachpersonal!

Attention: To prevent electrical shock, disconnect from power source before installing or servicing. Install in suitable enclosure. Keep free from contaminants. To be commissioned and maintained only by qualified personnel!

Atención: Con el objeto de evitar accidentes, hay que desconectar la alimentación eléctrica antes de realizar el montaje y la puesta en marcha. Debe instalarse en una caja o armario apropiado. Debe protegerse el producto de los ambientes agresivos. La puesta en marcha y el mantenimiento ha de hacerlo exclusivamente por personal especializado!

Attention: Avant le montage et la mise en service, couper l'alimentation secteur afin d'éviter tout accident. Prévoir une mise en coffret ou armoire appropriée, protéger le produit contre les environnements agressifs. Mise en service en entretien: seulement par du personnel spécialisé!

Attenzione: Per prevenire infortuni, togliere tensione prima dell'installazione o manutenzione. Installare in custodia idonea. Tenere lontano da contaminanti. Messa in servizio e manutenzione solo da personale specializzato!

注意 安装前或检修前应切断电源，以防事故。开关应安装在适合的箱体，同时应做好防污染保护。只有专业人员才能做运行、维护、保养的工作。

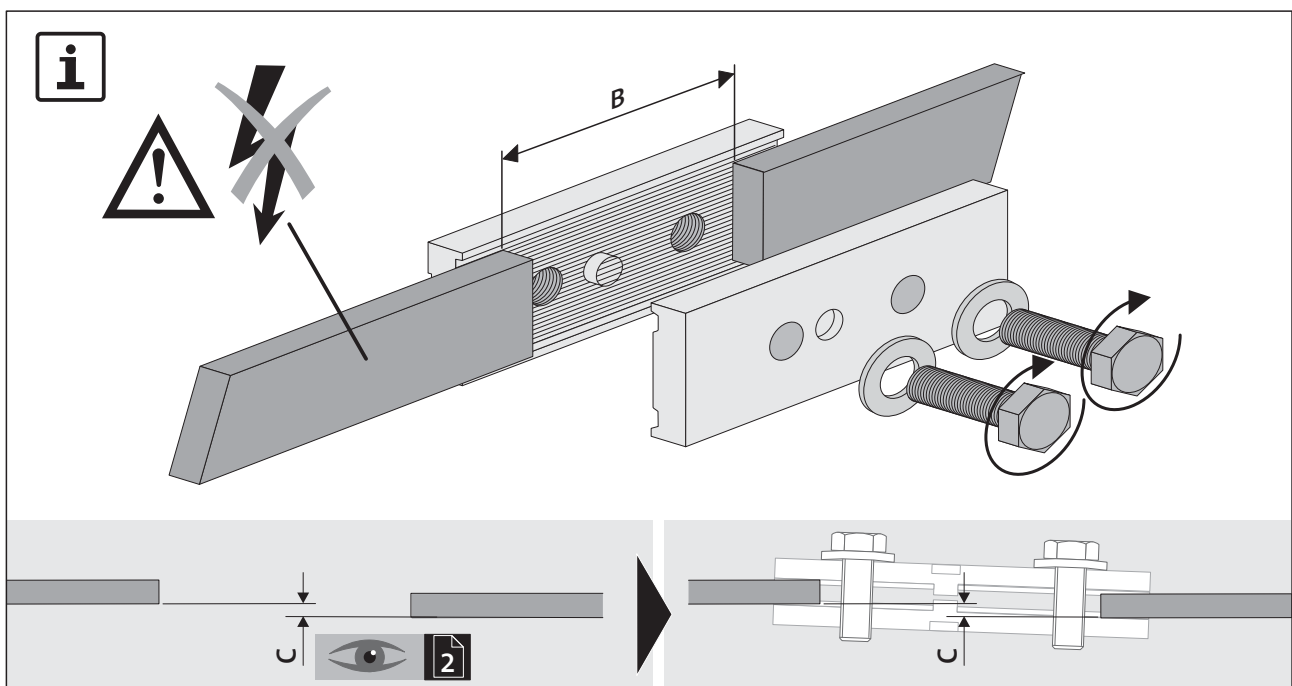

01 990

[mm]

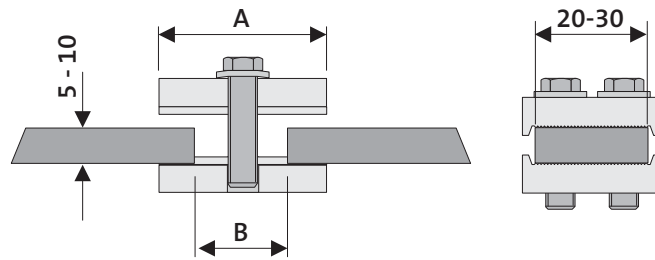

5 - 10 mm

01 823

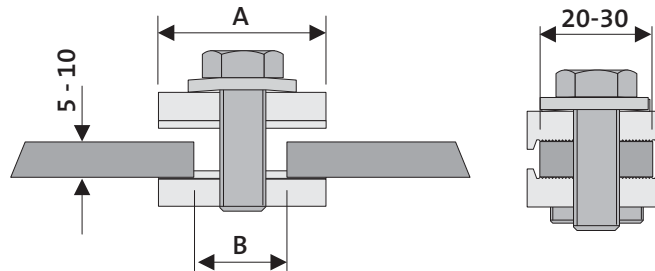

01 141, 01 886

5 mm

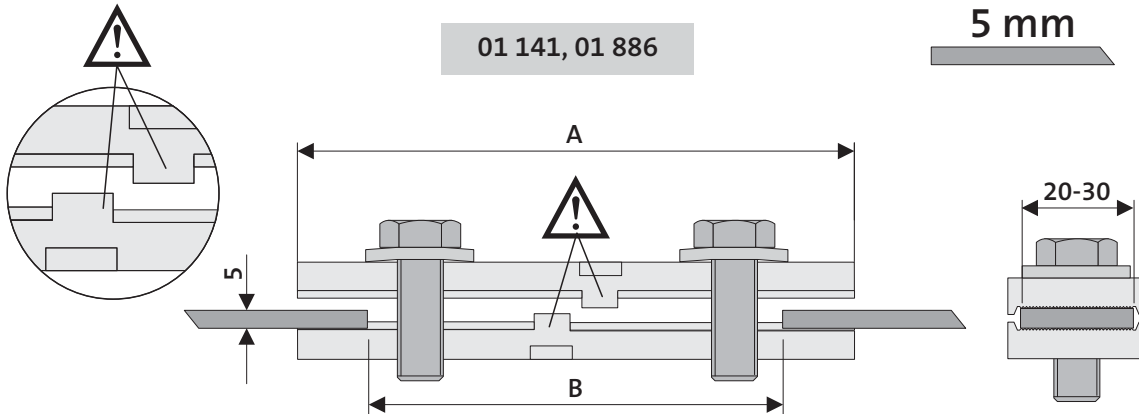

10 mm

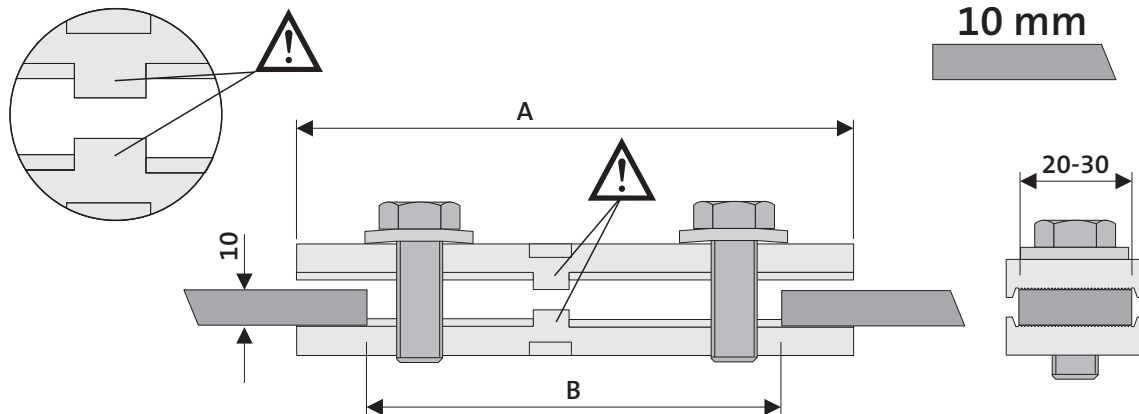

Art.	A	B	C	Klemmschraube clamping screw	Anzugdrehmoment tightening torque
01 990	40	9 - 20	< 2 mm	2 x M8	15 Nm / 135 lb. in.
01 823	40	13 - 20	< 2 mm	1 x M12	30 Nm / 270 lb. in.
01 141	95	50 - 60	< 3 mm	2 x M10	20 Nm / 180 lb. in.
01 886	150	100 - 110	< 3 mm	2 x M12	30 Nm / 270 lb. in.